

18" DRILL DEPTH MAIN FRAME ASSEMBLY

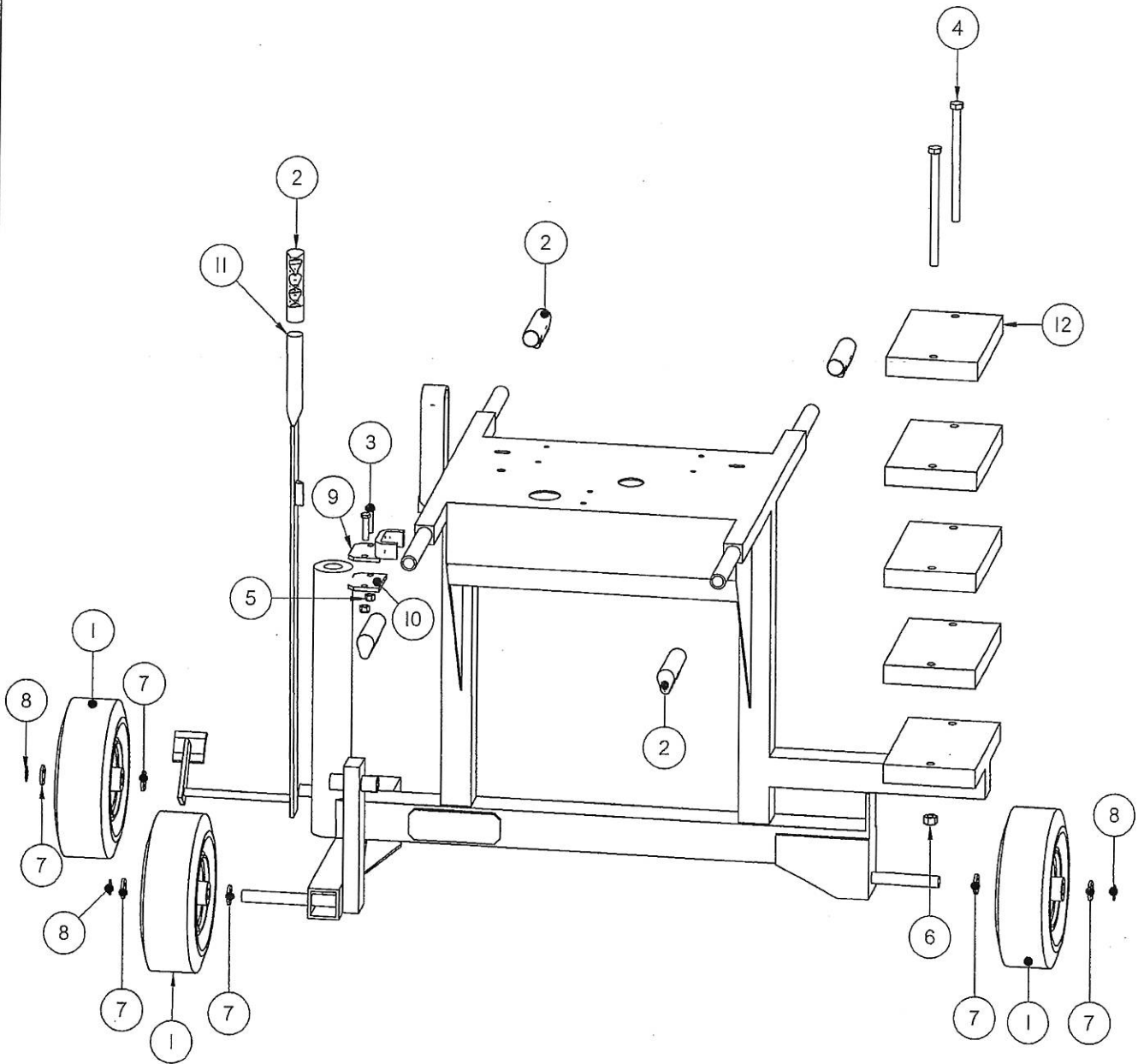

81406FNG-10

18"DRILL DEPTH MAIN FRAME ASSEMBLY

Item Number	File Name	Quantity	Description
1	0202WHL.asm	3	REAR WHEEL
2	1820GRO.par	5	HANDLE GRIP
3*	254IBLT.par	2	3/8" X 1 1/2" BOLT
4	2580BLT.par	2	1/2" X 7 1/2" BOLT
5	2727NUT.par	2	3/8" LOCKNUT
6	2734NUT.par	2	1/2" LOCKNUT
7	285IWAS.par	6	3/4" X 10 GA. WASHER
8	3038PIN.par	3	SNAP RING
9	MFA06841.par	1	SKEW LOCK
10*	MFA06842.par	1	SKEW LOCK PLATE
11	MNF05120.asm	1	MAIN FRAME
12	SRUI3059.par	4	COUNTER WEIGHT

81406FNG-20

18" DRILL DEPTH FEED BAR ASSEMBLY

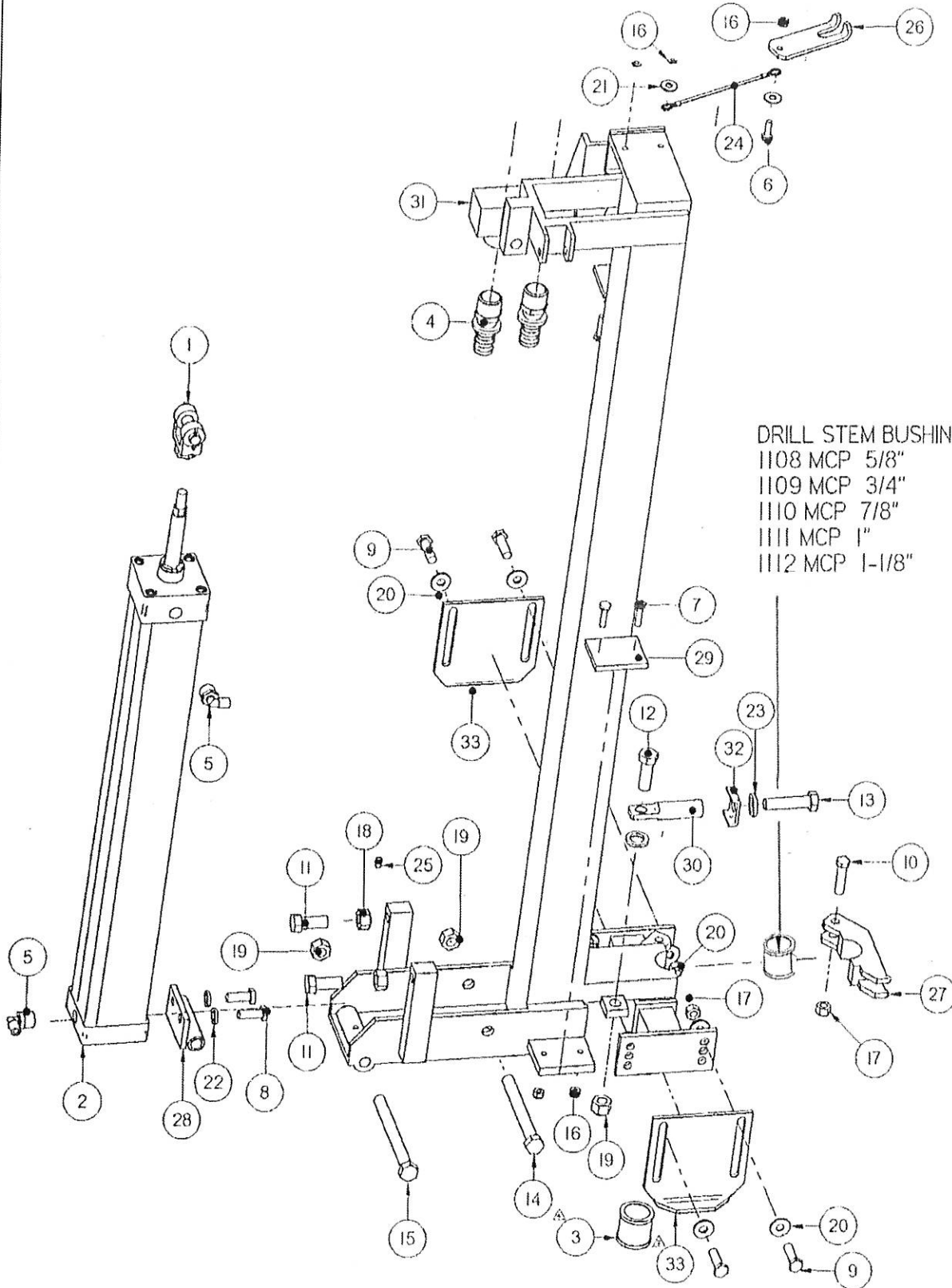

81406FNG-30

18" DRILL DEPTH FEED BAR ASSEMBLY

Item Number	File Name	Quantity	Description
1	0501cyl.asm	1	CLEVIS WITH PIN FOR 5/8" ROD
2	0514ICYL.asm	1	2.5" X 20" FEED CYLINDER
3	1112mcp.par	1	1 1/8" BUSHING
4*	1999fit.par	2	3/4" X 3/4" HOSE SWIVEL
5	2052fit.par	2	1/4" TO 3/8" 90 DEG. FITTING
6*	2501blt.par	1	1/4" X 3/4" BOLT
7*	2503blt.par	4	1/4" X 1" BOLT
8*	2538blt.par	2	3/8" X 1" BOLT
9	2540blt.par	4	3/8" X 1 1/4" BOLT
10	2541blt.par	1	3/8" X 1 1/2" BOLT
11	2560blt.par	2	1/2" X 1 1/4" BOLT
12*	2562blt.par	1	1/2" X 1 1/2" BOLT
13	2563blt.par	1	1/2" X 2" BOLT
14	2572blt.par	1	1/2" X 4 1/2" BOLT
15	2575blt.par	1	1/2" X 5" BOLT
16	2716nut.par	5	1/4" NYLON LOCK NUT
17	2727nut.par	5	3/8" LOCKNUT
18*	2732nut.par	2	1/2" STANDARD NUT
19	2734nut.par	3	1/2" LOCKNUT
20	2800was.par	8	5/16" FLAT WASHER
21	2801was.par	2	1/4" FLAT WASHER
22	2821was.par	2	3/8" LOCK WASHER
23	2831was.par	2	7/8"OD X 1/2"ID WASHER 10GA.
24*	3030pin.par	1	6" LANYARD WITH LOOPS
25	9501mis.par	1	GREASE ZERT
26	cra0218.par	1	CARRIAGE LOCK
27	mfa0609.par	1	BIT GUIDE
28	mfa06242.par	1	FEED CYLINDER MOUNT 210 SR
29*	mfa0626.par	2	STOP PAD
30*	mfa0674.par	1	SWIVEL BOLT
31	mfa0686.par	1	FEED BAR
32*	mfa0690.par	1	BIT GUIDE KEEPER
33	mob0917.par	2	AUTO ALIGN STOP

81406FNG-40

18" DRILL DEPTH FEED BAR ASSEMBLY: A

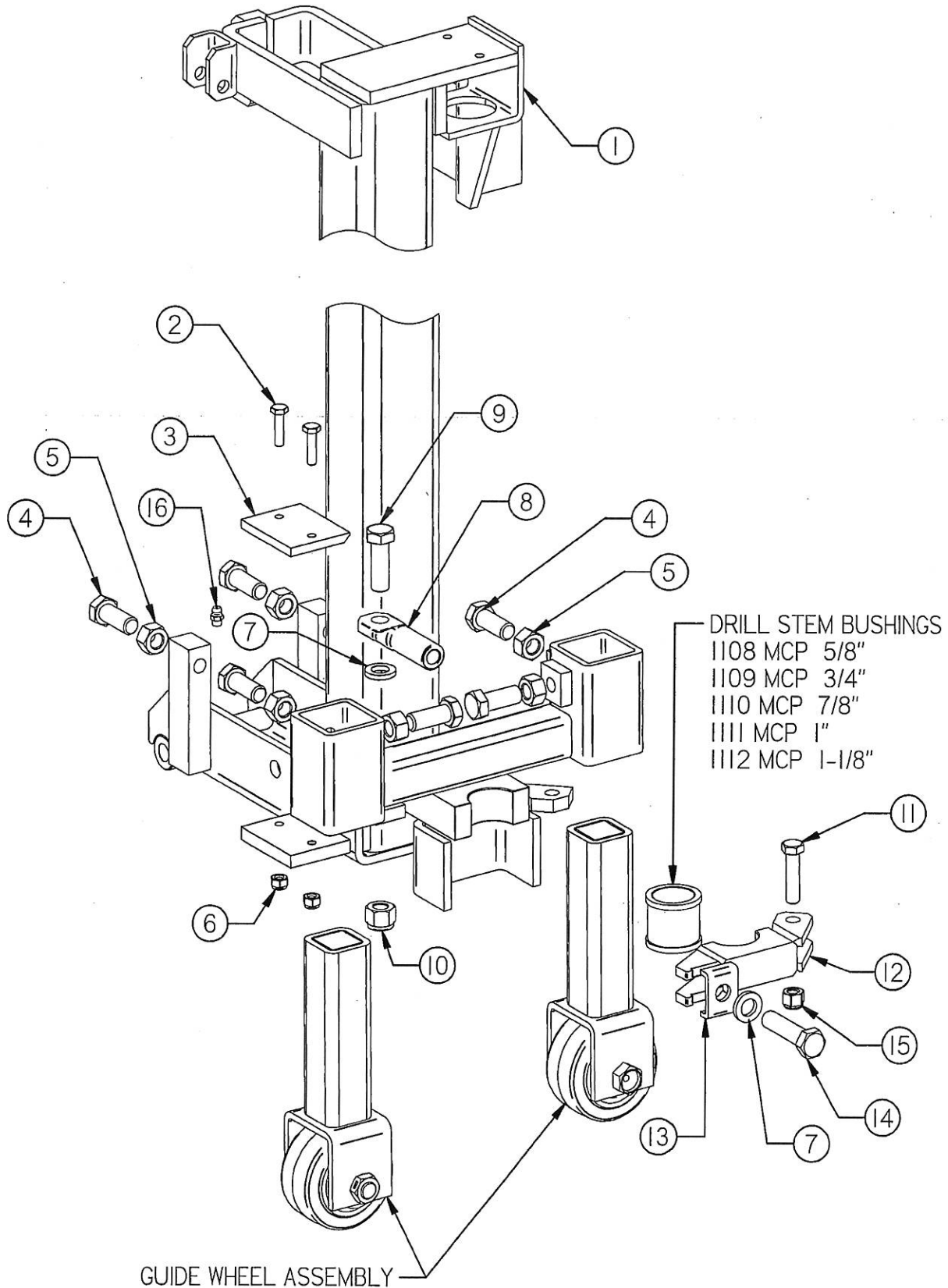

18" DRILL DEPTH FEED BAR ASSEMBLY: A

Item No.	Part No.	Quantity	Description
1	MFA0686	1	18" DEPTH FEED BAR (210B SRA)
2	2503BLT	2	1/4" NC X 1.00" BOLT, GR. 5
3	MFA0626	1	STOP PAD
4	2560BLT	6	1/2" NC X 1.25" HX HD BOLT
5	2732 NUT	6	1/2" NC STANDARD NUT
6	2716NUT	2	1/4" NC NYLON LOCK NUT
7	283IWAS	2	7/8" OD X 1/2" ID WASHER 10GA.
8	MFA0674	1	SWIVEL BOLT (1/2-13UNC)
9	2562 BLT	1	1/2" NC X 1.50" HX HD TAP BOLT
10	2734NUT	1	1/2" NC NYLON INSERT LOCKNUT
11	2541 BLT	1	3/8" NC X 1.50" HX HD BOLT
12	MFA0609	1	LOWER BIT GUIDE (1.38")
13	MFA0690	1	BIT GUIDE KEEPER
14	2563 BLT	1	1/2" NC X 2.00" HX HD BOLT
15	2727NUT	1	3/8" NC NYLON INSERT LOCKNUT
16	9501 MIS	1	1/4-28 NF ST. GREASE ZERK

18" DRILL DEPTH FEED BAR ASSEMBLY: B

0501 CYL ASSEMBLY

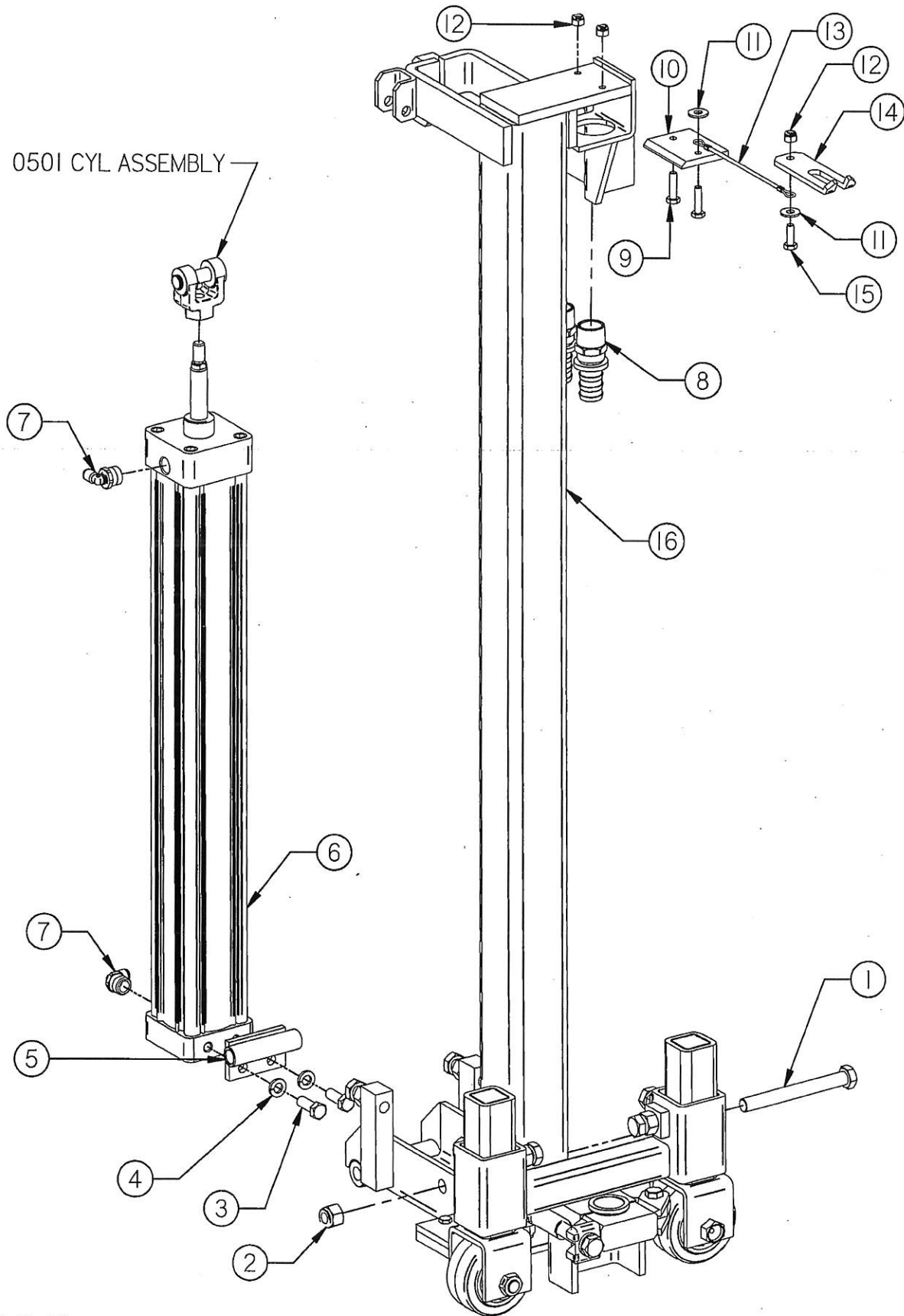

2-12-13

81406FNG - PARTS PAGE 05

18" DRILL DEPTH FEED BAR ASSEMBLY: B

Item No.	Part No.	Quantity	Description
1	2572BLT	1	1/2" NC X 4 1/2" BOLT, GR. 5
2	2734NUT	1	1/2" NC NYLON INSERT LOCKNUT
3	2538 BLT	2	3/8" NC X 1.00" HX HD BOLT
4	2821 WAS	2	3/8" LOCK WASHER
5	MFA06242	1	FEED CYLINDER MONT
6	051415 CYL	1	PNEUMATIC CYLINDER 2.50 X 20" STROKE
7	2052 FIT	2	1/4" TUBE X 3/8" NPT 90 DEG. SWIVEL
8	1999 FIT	2	3/4" NPT MALE X 3/4" HOSE SWIVEL
9	2503BLT	2	1/4" NC X 1.00" BOLT, GR. 5
10	MFA0626	1	STOP PAD
11	2801 WAS	2	1/4" FLAT WASHER
12	2716NUT	3	1/4" NC NYLON LOCK NUT
13	3030PIN	1	6" LANYARD WITH LOOPS
14	CRA0218	1	CARRIAGE LOCK
15	2501BLT	1	1/4" NC X .75" HX HD BOLT
16	MFA0686	1	18" DEPTH FEED BAR (210B SRA)

GUIDE WHEEL ASSEMBLY (STANDARD)

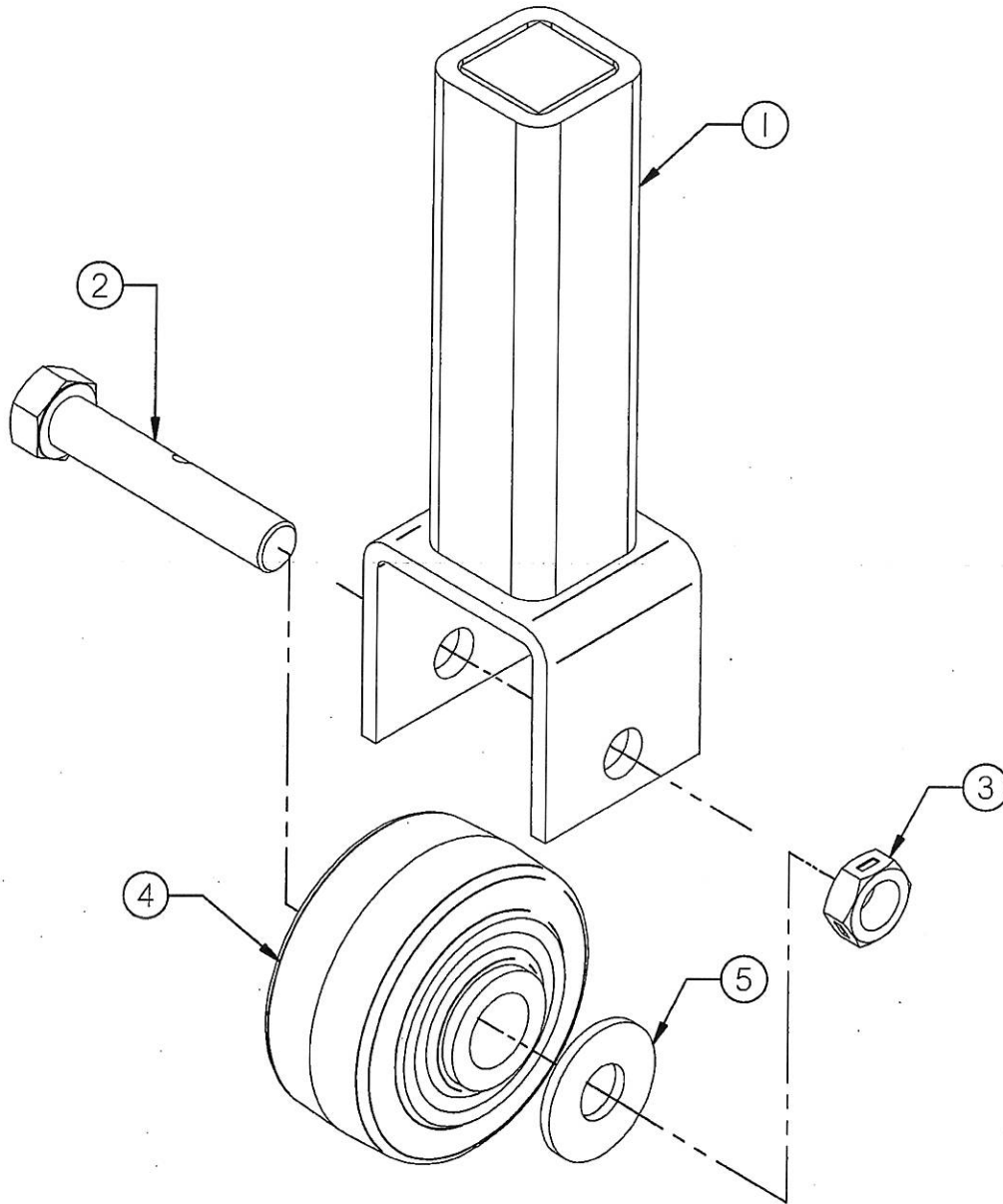

Item No.	Part No.	Quantity	Description
1	MOB09280	1	GUIDE WHEEL BRACKET, 210B SRA
2	25674BLT	1	1/2" X 2-3/4" GREASE BOLT
3	25674 NUT	1	1/2-13 GREASE BOLT LOCK NUT
4	0207 WHL	1	GUIDE WHEEL (210B SRA)
5	2830 WAS	1	1/2" STD. FLAT WASHER

SRA FEED BAR EXTENSION

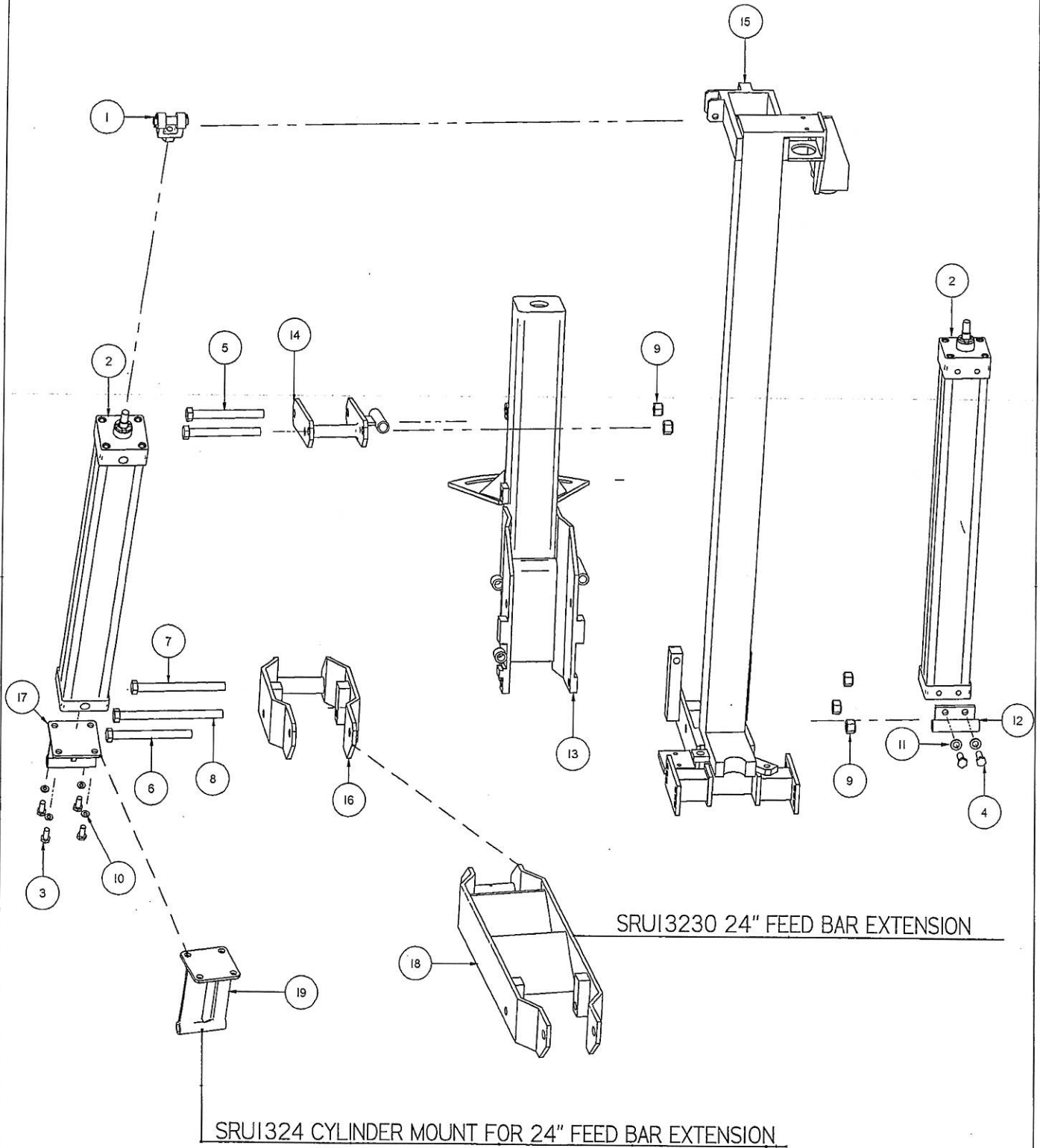

SRUI3230 24" FEED BAR EXTENSION

SRUI324 CYLINDER MOUNT FOR 24" FEED BAR EXTENSION

SRA FEED BAR EXTENSION

Item Number	File Name	Quantity	Description
1	0501cyl.asm	1	CLEVIS WITH PIN FOR 5/8" ROD
2	0514ICYL.asm	2	2.5" X 20" FEED CYLINDER
3	2516blt.par	4	5/16" X 3/4" FINE THREAD BOLT
4	2538blt.par	2	3/8" X 1" BOLT
5	2572blt.par	2	1/2" X 4 1/2" BOLT
6	2575blt.par	1	1/2" X 5" BOLT
7	2576blt.par	1	1/2" X 5 1/2" BOLT
8	2578blt.par	1	1/2" X 6 1/2" BOLT
9	2734nut.par	5	1/2" LOCKNUT
10	2810was.par	4	5/16" LOCK WASHER
11	2821was.par	2	3/8" LOCK WASHER
12	mfa06242.par	1	FEED CYLINDER MOUNT 210 SR
13	mfa06500.par	1	MAST WITH SKEW ADJUST 210 SRA
14	mfa0678.par	1	ALIGNMENT ARM
15	mfa0686.par	1	FEED BAR
16	srui323.par	1	18" FEED BAR EXTENSION
17	srui3231.par	1	CYLINDER MOUNT FOR 18" FEED BAR EXTENSION
18	SRUI3230.par	1	24" FEED BAR EXTENSION
19	SRUI324.par	1	CYLINDER MOUNT 24" FEED BAR EXTENSION

FCP 5000 18" FEED BAR EXTENSION INCLUDES:

FCP 5001 24" FEED BAR EXTENSION INCLUDES:

1- SRUI323 18" FEED BAR EXTENSION

1- SRUI3230 24" FEED BAR EXTENSION

1- SRUI3231 CYLINDER MOUNT 18" FEED BAR EXT.

1- SRUI324 CYLINDER MOUNT 24" FEED BAR EXT.

1- 2575BLT 1/2" X5" BOLT

1- 2575BLT 1/2" X5" BOLT

1- 2576BLT 1/2" X 5 1/2" BOLT

1- 2576BLT 1/2" X 5 1/2" BOLT

1- 2578BLT 1/2" X 6 1/2" BOLT

1- 2578BLT 1/2" X 6 1/2" BOLT

3- 2734NUT 1/2" NYLON LOCK NUT

3- 2734NUT 1/2" NYLON LOCK NUT

2- 2065FIT 1/4" X 1/4" SPLICE

2- 2065FIT 1/4" X 1/4" SPLICE

2' - 1903HOS 1/4" BLACK TUBE

2' - 1903HOS 1/4" BLACK TUBE

81406FNG-60

18" DRILL DEPTH CARRIAGE ASSEMBLY

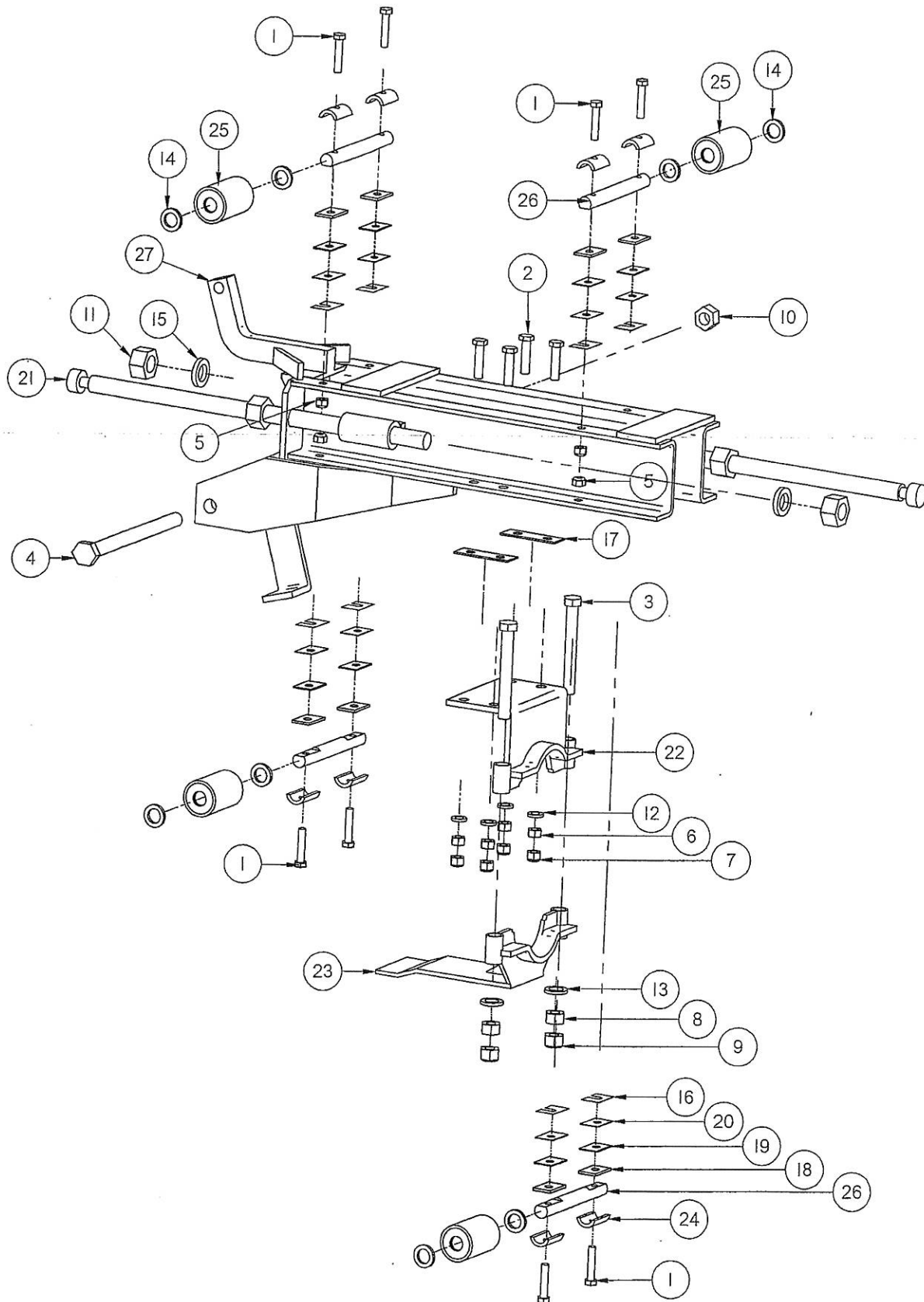

81406FNG-70

18" DRILL DEPTH CARRIAGE ASSEMBLY

Item Number	File Name	Quantity	Description
1	2526BLT.par	8	5/16" X 1 1/2" BOLT
2	2541BLT.par	4	3/8" X 1 1/2" BOLT
3	2570BLT.par	2	1/2" X 4" BOLT
4	2590BLT.par	1	5/8" X 8" BOLT
5	2719NUT.par	8	5/16" NYLON LOCK NUT
6	2725NUT.par	4	3/8" STANDARD NUT
7	2727NUT.par	4	3/8" LOCKNUT
8	2732NUT.par	2	1/2" STANDARD NUT
9	2734NUT.par	2	1/2" LOCKNUT
10	2742NUT.par	1	5/8" LOCKNUT
11	27490NUT.par	4	3/4" COIL ROD NUT
12	2821WAS.par	4	3/8" LOCK WASHER
13	2832WAS.par	2	1/2" LOCK WASHER
14	2841WAS.par	8	5/16" WASHER
15	2852WAS.par	2	3/4" LOCK WASHER
16	7009TAB.par	8	STAINLESS STEEL SHIM (AS NEEDED)
17	7010TAB.par	2	16 GA. TWO HOLE SHIM
18	7011TAB.par	8	12 GA. SHIM (AS NEEDED)
19	7012TAB.par	8	18 GA. SHIM (AS NEEDED)
20	7013TAB.par	8	22 GA. SHIM (AS NEEDED)
21	Cra02030.Par	2	18" STOP ROD
22	CRA0214.par	1	UPPER DRILL BRACKET
23	CRA0216.par	1	LOWER DRILL BRACKET
24	CRA0230.par	8	BEARING KEEPER
25	CRA0233.par	4	ROLLER BEARING DRUM
26	CRA0234.par	4	ROLLER BEARING AXLE
27	CRG01101.par	1	CARRIAGE

81406FNG-80

18" DRILL DEPTH MAST ASSEMBLY

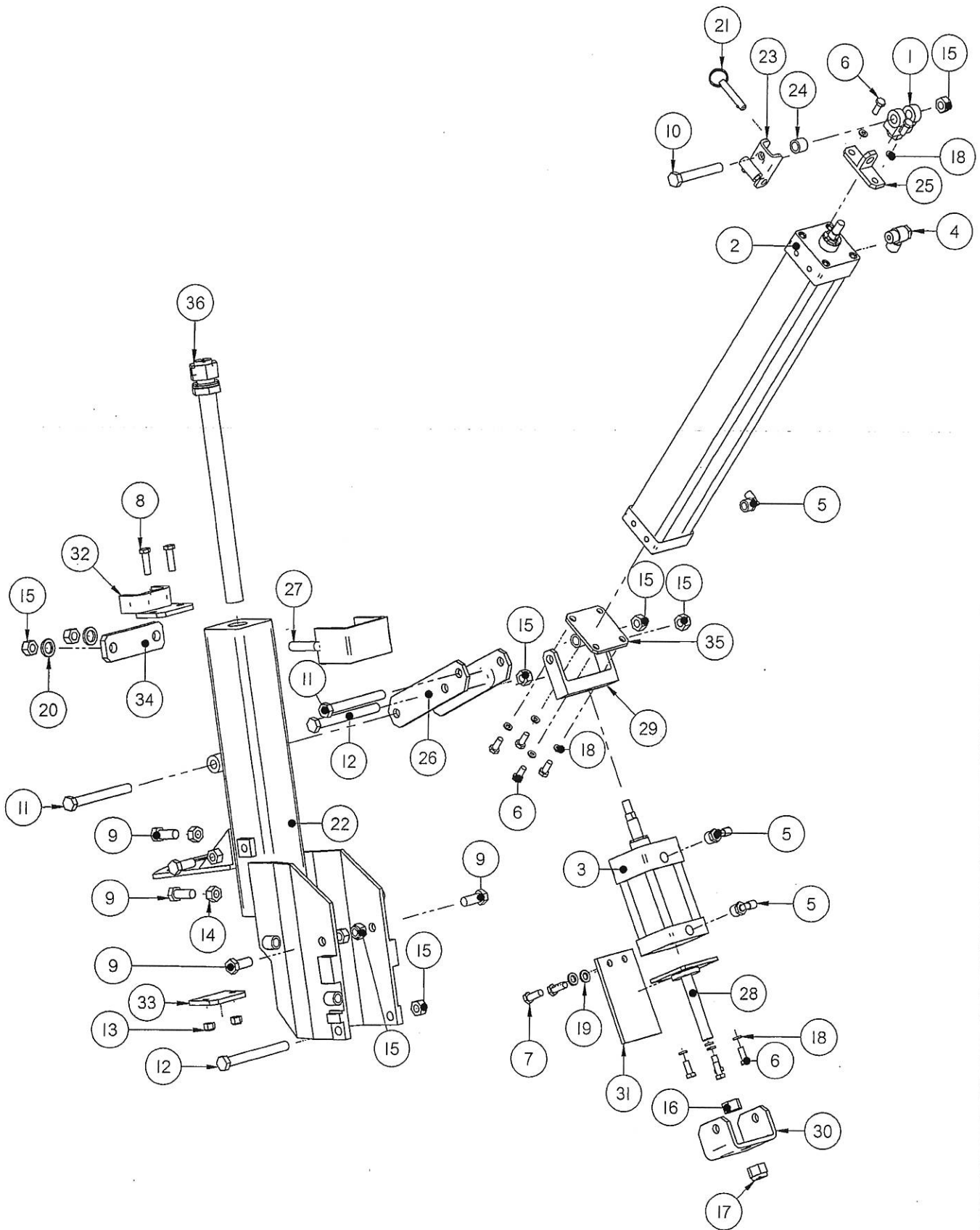

81406FNG-90

18" DRILL DEPTH MAST ASSEMBLY

Item Number	File Name	Quantity	Description
1	0501cyl.par	1	CYLINDER CLEVIS
2'	05141CYL.asm	1	2.5" X 20" FEED CYLINDER
3'	052101CYL.asm	1	2 1/2" X 2" CYLINDER
4	0611val.par	1	FLOW CONTROL VALVE
5	2052fit.par	3	1/4" TO 3/8" 90 DEG. FITTING
6	2516bolt.par	10	5/16" X 3/4" FINE THREAD BOLT
7	2538bolt.par	2	3/8" X 1" BOLT
8	2540bolt.par	2	3/8" X 1 1/4" BOLT
9	2560bolt.par	5	1/2" X 1 1/4" BOLT
10	2568bolt.par	1	1/2" X 3 1/2" BOLT
11	2572bolt.par	2	1/2" X 4 1/2" BOLT
12	2575bolt.par	2	1/2" X 5" BOLT
13	2727nut.par	2	3/8" LOCKNUT
14	2732nut.par	3	1/2" STANDARD NUT
15	2734nut.par	9	1/2" LOCKNUT
16"	2740nut.par	1	5/8" STANDARD NUT
17	2743nut.par	1	5/8" NYLON LOCK NUT
18	2810was.par	10	5/16" LOCK WASHER
19	2821was.par	2	3/8" LOCK WASHER
20	2831was.par	2	7/8"OD X 1/2"ID WASHER 10GA.
21	3029pin.par	1	LOCK PIN
22'	mfa06500.par	1	MAST WITH SKEW ADJUST 210 SRA
23	mfa0672.par	1	CYLINDER LOCK CLEVIS 4 WAY
24	mfa06721.par	1	CYLINDER LOCK CLEVIS SPACER
25	mfa0673.par	1	CYLINDER LOCK
26'	mfa0678.par	1	ALIGNMENT ARM
27	mfa0680.par	1	VERTICAL ADJUSTING BRACKET
28'	mfa0682.par	1	CYLINDER ADJUST AUTO ALIGN
29	mfa0683.par	1	AUTO ALIGN CLEVIS
30	mfa0684.par	1	PIVOT AUTO ALIGN
31	mfa06840.par	1	RETAINING PLATE FOR AUTO ALIGN CYLINDER
32	mfa06841.par	1	SKEW LOCK
33	mfa06842.par	1	SKEW LOCK PLATE
34'	mfa0689.par	1	VERTICAL ADJUSTMENT CLAMP STRAP
35	srg1120.par	1	CYLINDER MOUNT BRACKET
36	srul301.asm	1	SCREW JACK ASSEMBLY

81406FNG-100

MAST EXTENSION ASSMEEBLY

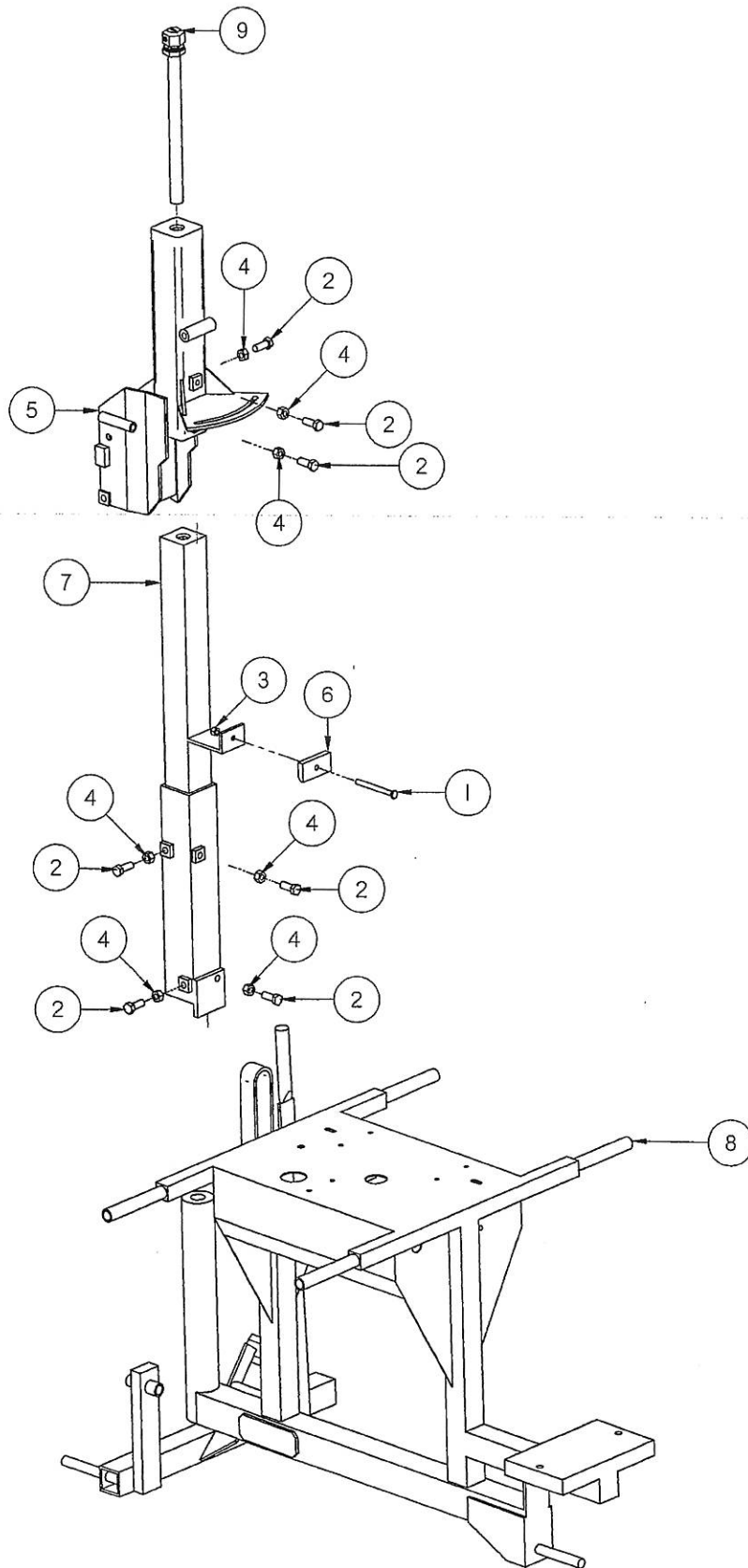

81406FNG-110

MAST EXTENSION ASSEMBLY

Item Number	File Name	Quantity	Description
1	2551BLT.par	1	3/8" X 3 3/4" BOLT
2	2560BLT.par	7	1/2" X 1 1/4" BOLT
3	2727NUT.par	1	3/8" LOCKNUT
4	2732NUT.par	7	1/2" STANDARD NUT
5	MFA06500.par	1	MAST WITH SKEW ADJUST 210 SRA
6	MFA06502.par	1	MAST EXTENSION CLAMP
7	MFA06502.par	1	MAST EXTENSION
8	MNF05120.asm	1	MAIN FRAME
9	SRUI301.asm	1	SCREW JACK ASSEMBLY

81406FNG-120

SCREW JACK ASSEMBLY

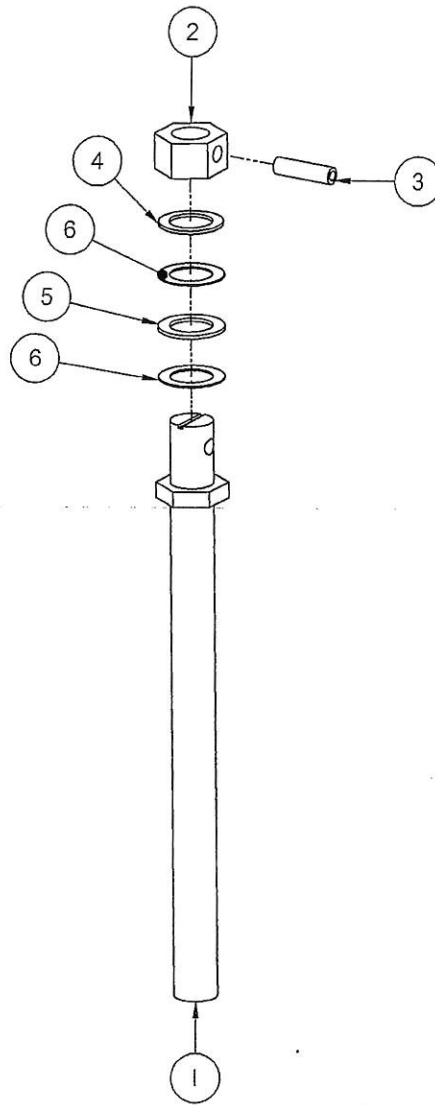

Item Number	File Name	Quantity	Description
1	SRUI301.par	1	SCREW JACK
2	SRUI301..par	1	NUT SCREW JACK ASSEMBLY
3	3006PIN.par	1	3/8" X 1 1/2" ROLL PIN
4	2860WAS.par	1	1 1/2" OD X 1" ID 5GA. WASHER
5	0408BRG.par	1	THRUST BEARING
6	04080BRG.par	2	THRUST BEARING WASHER

81406FNG-130

CYLINDER CLEVIS ASSEMBLY

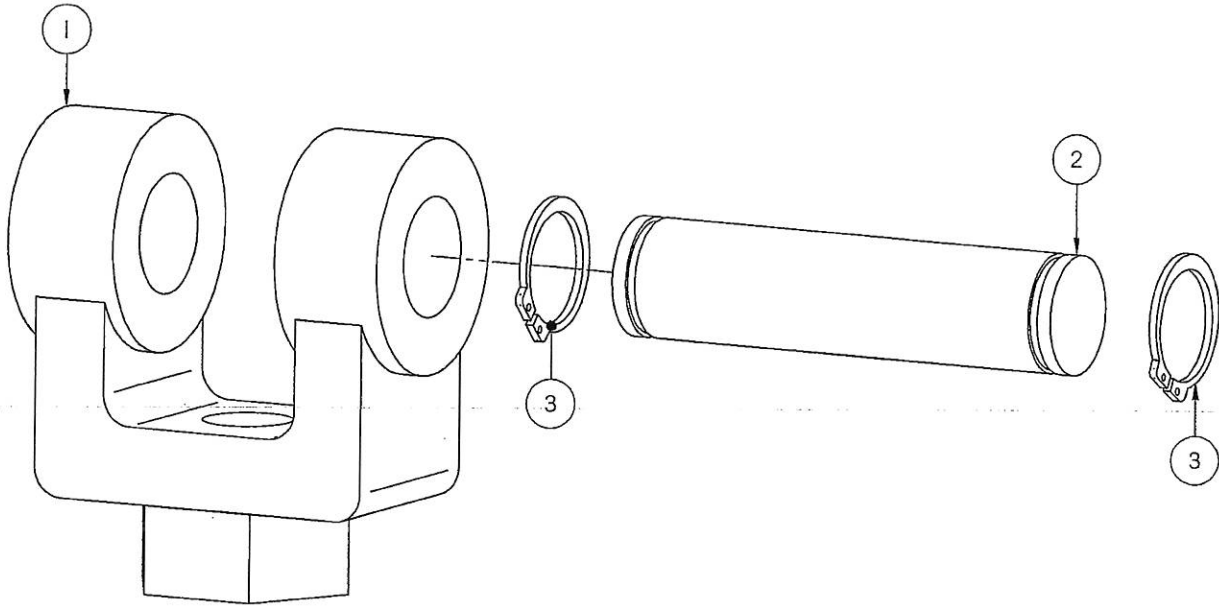

Item Number	File Name	Quantity	Description
1	0501CYL.par	1	CYLINDER CLEVIS
2	3002PIN.par	1	CYLINDER CLEVIS PIN
3	3002PIN...par	2	SNAP RING

81406FNG-140

HOSE ASSEMBLIES

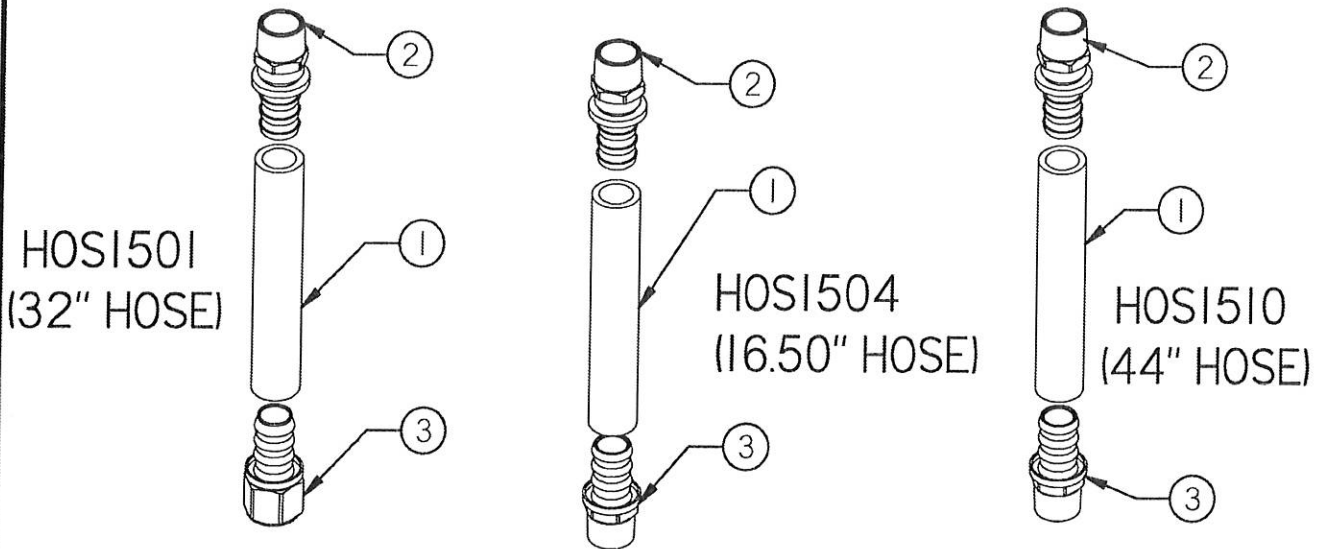

HOSI501

Item No.	Part No.	Quantity	Description
1	1904 HOS	1	3/4" PUSH ON HOSE
2	1999 FIT	1	3/4" NPT MALE X 3/4" HOSE SWIVEL
3	19989 FIT	1	3/4" NPT FEMALE X 3/4" HOSE NON-SWIVEL

HOSI504

Item No.	Part No.	Quantity	Description
1	1904 HOS	1	3/4" PUSH ON HOSE
2	1999 FIT	1	3/4" NPT MALE X 3/4" HOSE SWIVEL
3	2003 FIT	1	3/4" NPT MALE X 3/4" HOSE SWIVEL

HOSI510

Item No.	Part No.	Quantity	Description
1	1904 HOS	1	3/4" PUSH ON HOSE
2	1999 FIT	1	3/4" NPT MALE X 3/4" HOSE SWIVEL
3	2003 FIT	1	3/4" NPT MALE X 3/4" HOSE SWIVEL

18" DRILL DEPTH CONTROL PANEL ASSEMBLY

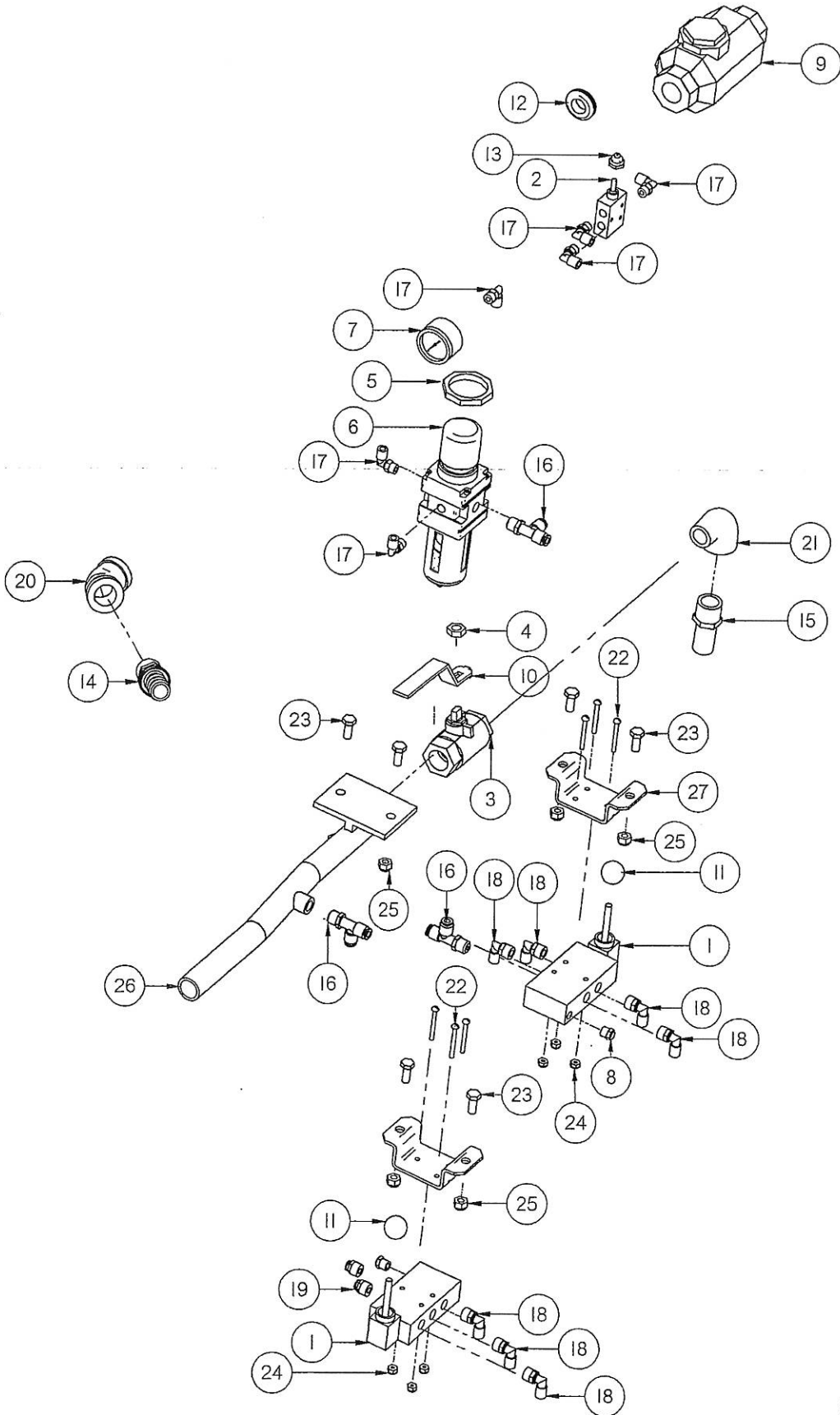

81406FNG-160

18" DRILL DEPTH CONTROL PANEL ASSEMBLY

Item Number	File Name	Quantity	Description
1	060102VAL.par	2	3 WAY POSITION VALVE WITH KNOB
2	06095VAL.par	1	TOGGLE SWITCH
3	0615VAL.par	1	3/4" BRASS BALL VALVE
4	0615VALNUT.par	1	NUT
5	17058 RPT.	1	LOCK RING FOR 08092REG
6	08092REG.par	1	AIR PRESSURE REGULATOR
7	09022GAU.par	1	GAUGE 0-60 1/8" MPT
8	1001BRV.par	2	1/8" BREATHER VENT
9	1601OIL.par	1	3/4" PINT OILER
10	17415RPT.par	1	BALL VALVE HANDLE
11	174201RPT.par	2	KNOB
12	1804GR0.par	1	RUBBER GROMET
13	1828GR0.par	1	RED BOOT FOR 06095VAL
14	1999FIT.par	1	3/4" X 3/4" HOSE SWIVEL
15	2003FIT.par	1	3/4" HOSE FITTING
16	2035FIT.par	3	1/4" X 1/4" MALE RUN T
17	2050FIT.par	6	1/4" TO 1/8" 90 DEG. FITTING
18	2051FIT.par	7	1/4" TO 1/4" 90 DEG. FITTING
19	2067FIT.par	2	1/4" TO 1/4" MALE CONNECTOR
20	2149PFT.par	1	3/4" 45DEG. ELBOW
21	2155PFT.par	1	3/4" STREET ELL
22	2478BLT.par	6	8/32" X 1 1/2" BOLT
23	2519BLT.par	6	5/16" X 3/4" BOLT
24	2712NUT.par	6	8/32" NYLON LOCK NUT
25	2719NUT.par	6	5/16" NYLON LOCK NUT
26	MFA0652.par	1	MANIFOLD (210)
27	SRUI3460.psm	2	VALVE SPACER

81406FNG-170

18" DRILL DEPTH CONTROL PANEL SCHEMATIC

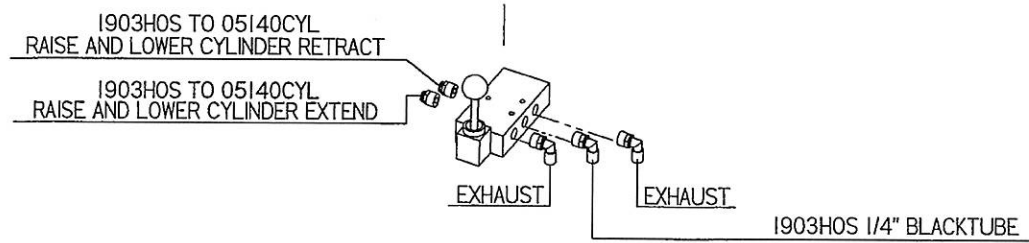
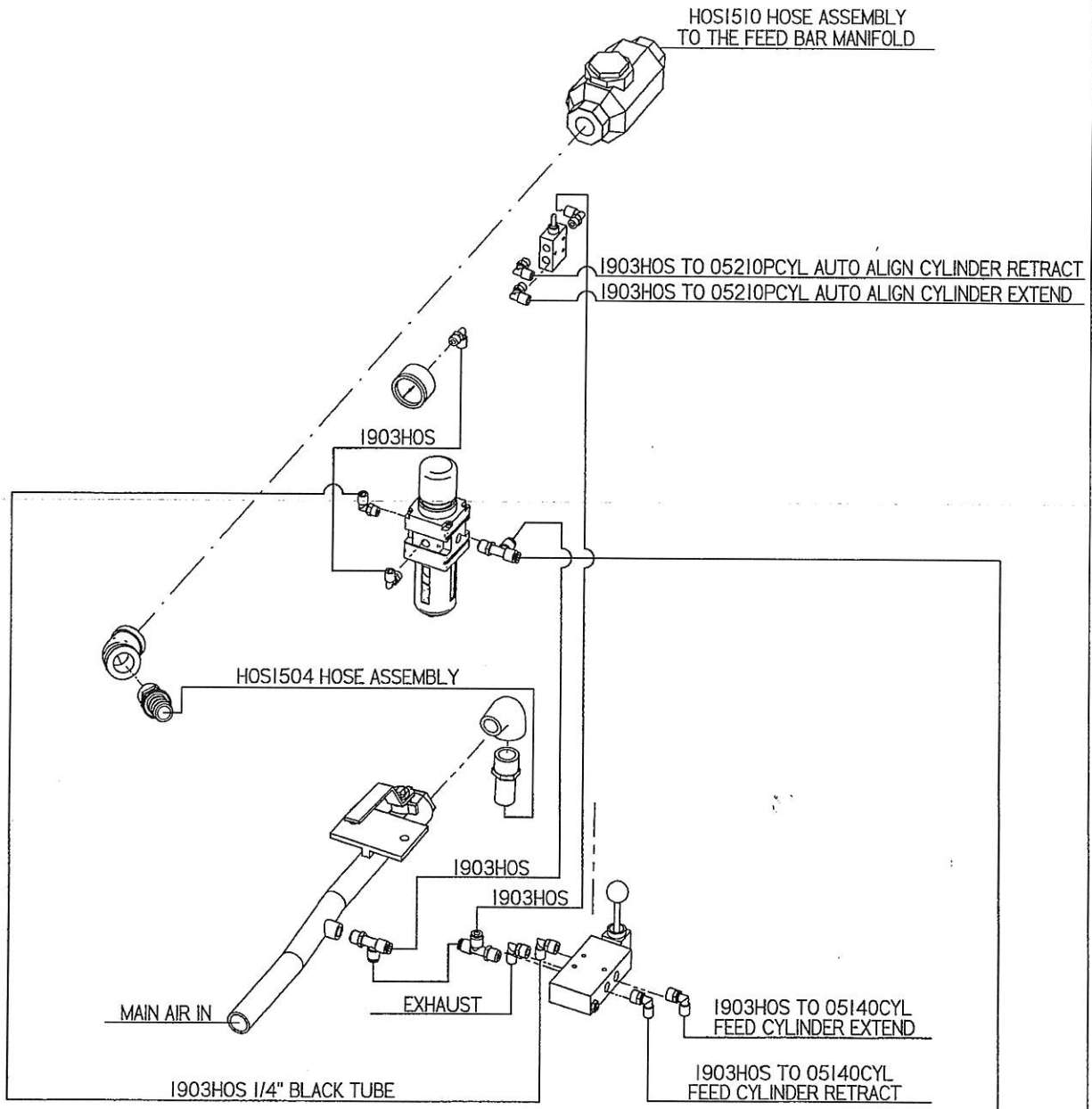

FEED BAR AND CYLINDER SCHEMATIC

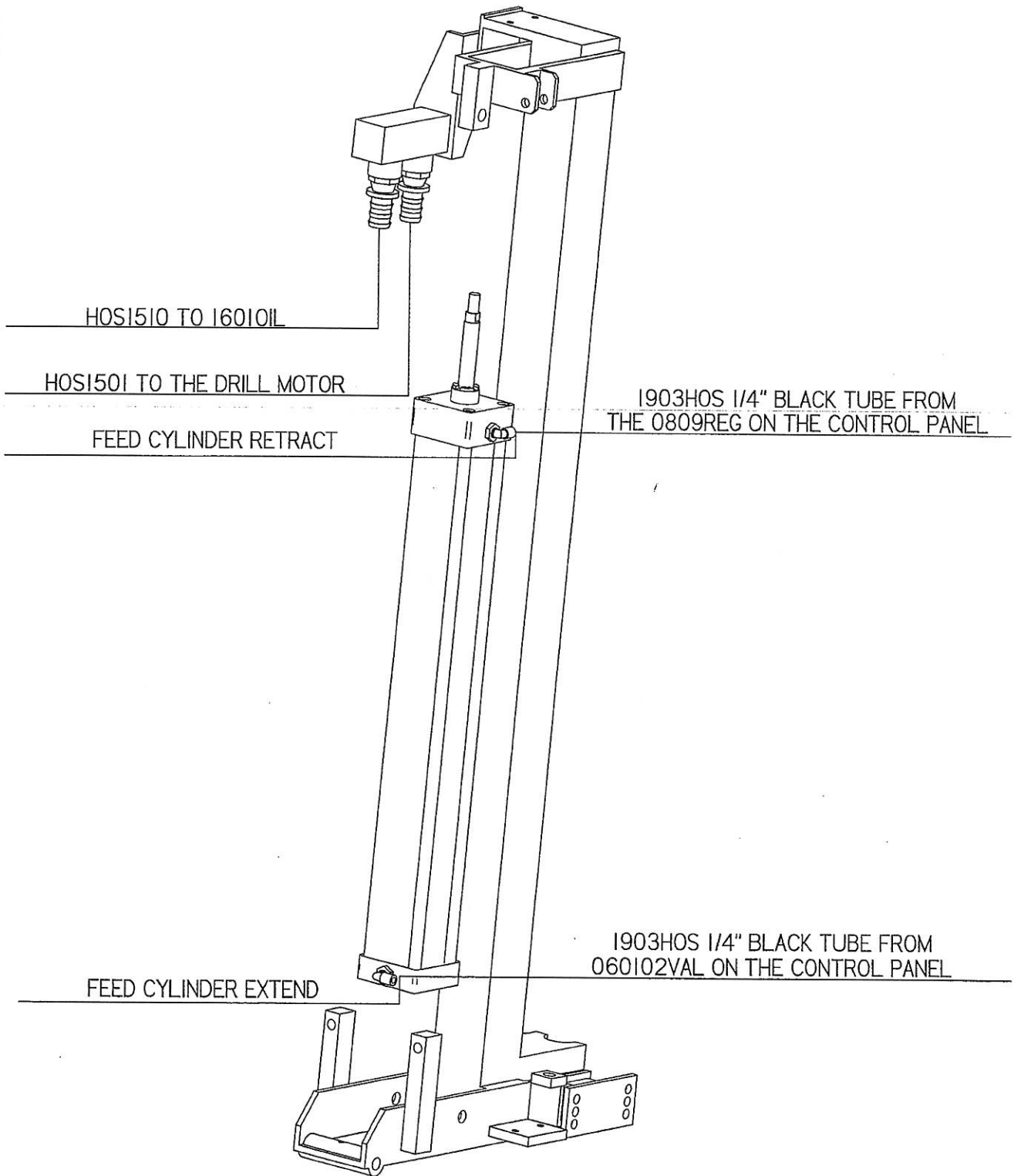

81406FNG-190

RAISE AND LOWER AND AUTO ALIGN CYLINDER SCHEMATICS 18" DRILL DEPTH

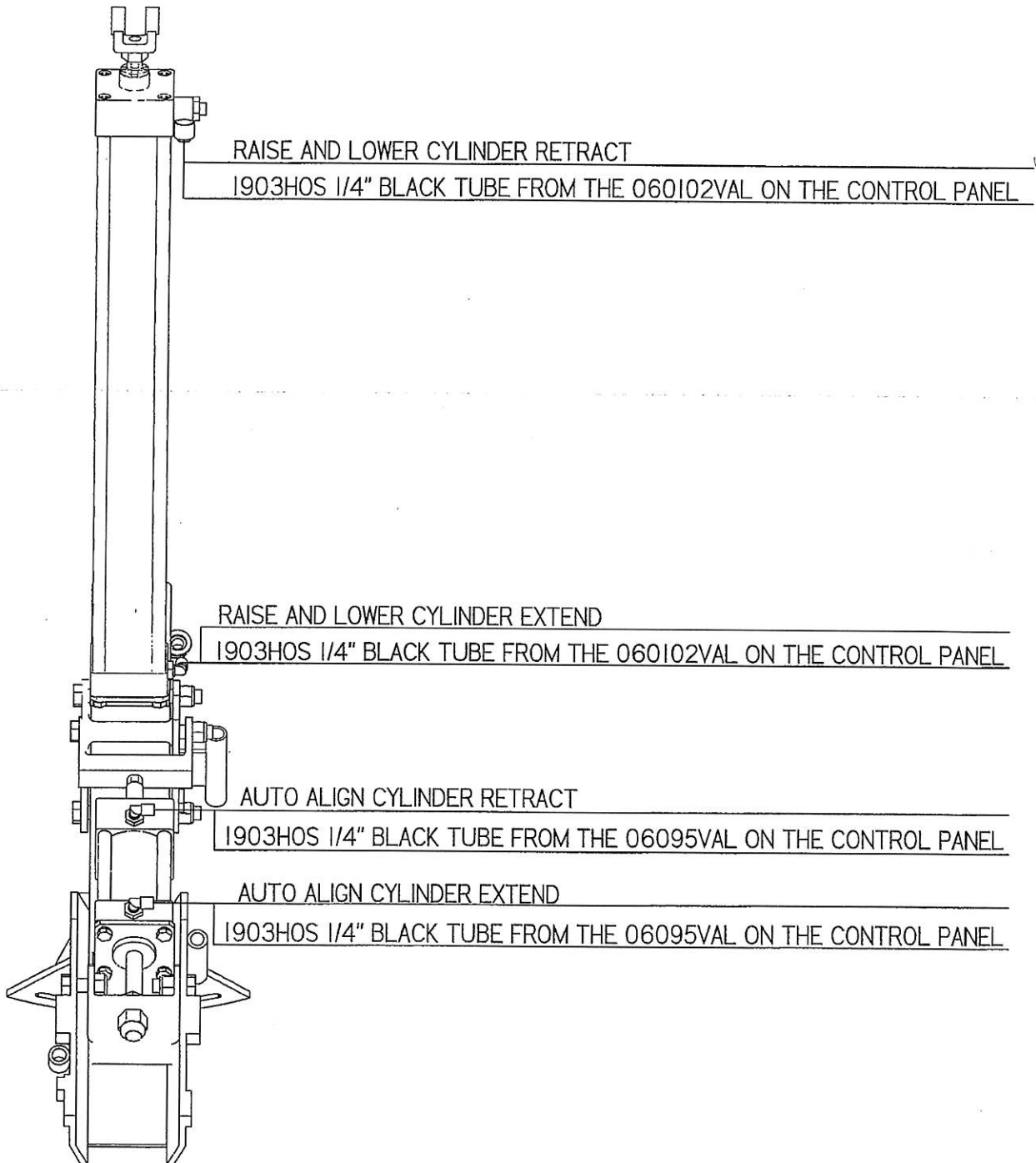

81406FNG-200

MAIN FRAME ASSEMBLY 24" DRILL DEPTH

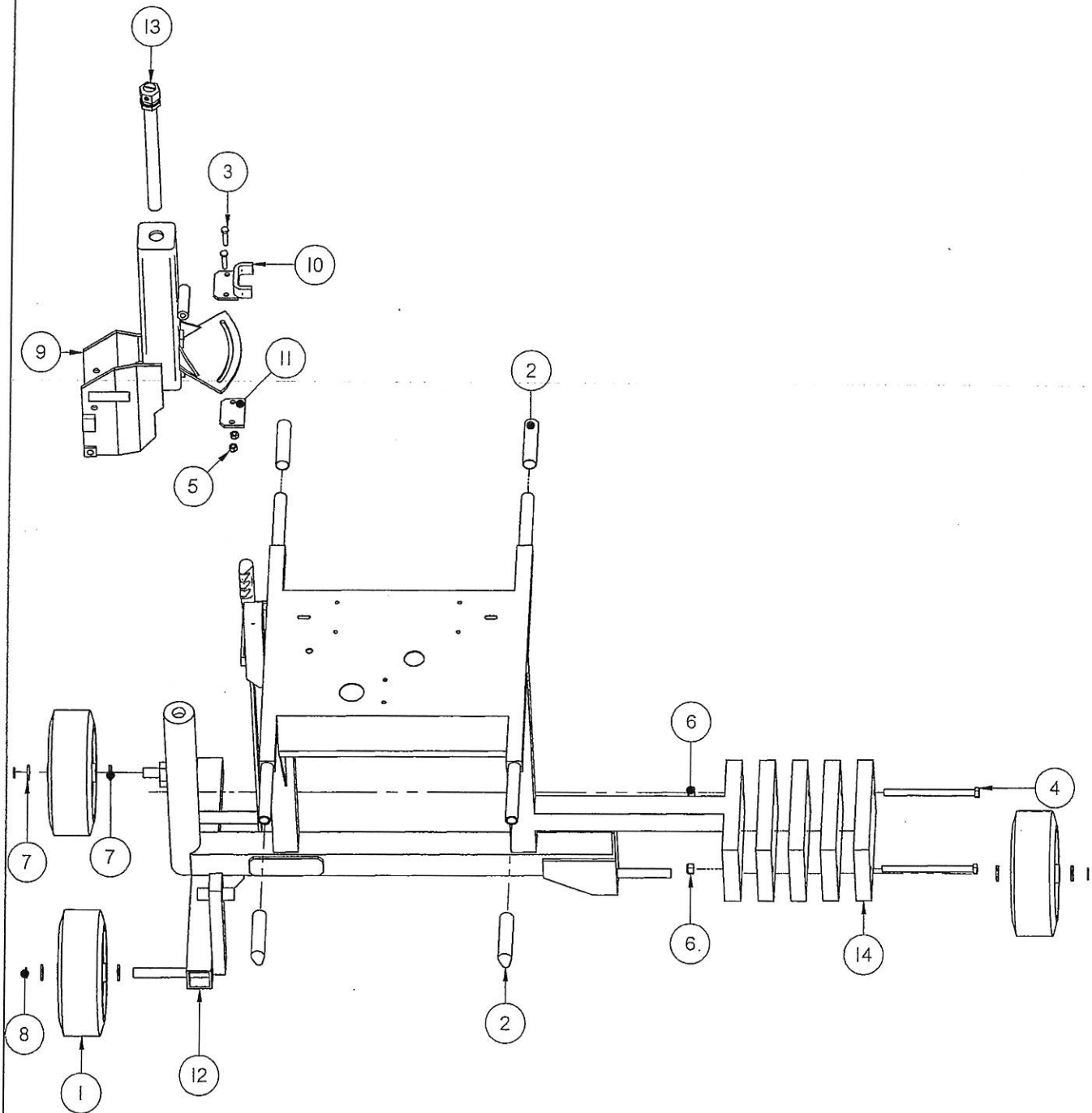

8140IFNG-10

MAIN FRAME ASSEMBLY 24" DRILL DEPTH

Item Number	File Name	Quantity	Description
1	0202WHL.asm	3	REAR WHEEL
2	1820GRO.par	5	HANDLE GRIP
3	254IBLT.par	2	3/8" X 1 1/2" BOLT
4	2580BLT.par	2	1/2" X 7 1/2" BOLT
5	2727NUT.par	2	3/8" LOCKNUT
6	2734NUT.par	2	1/2" LOCKNUT
7	285IWAS.par	6	3/4" X 10 GA. WASHER
8*	3036PIN.par	3	SNAP RING
9	MFA06500.par	1	MAST WITH SKEW ADJUST 210 SRA
10	MFA06841.par	1	SKEW LOCK
11*	MFA06842.par	1	SKEW LOCK PLATE
12	MNF05121.asm	1	MAIN FRAME 24" DRILL DEPTH SRA
13	SRUI301.asm	1	SCREW JACK ASSEMBLY
14	SRUI3059.par	4	COUNTER WEIGHT

8140IFNG-20

24" DRILL DEPTH FEED BAR ASSEMBLY

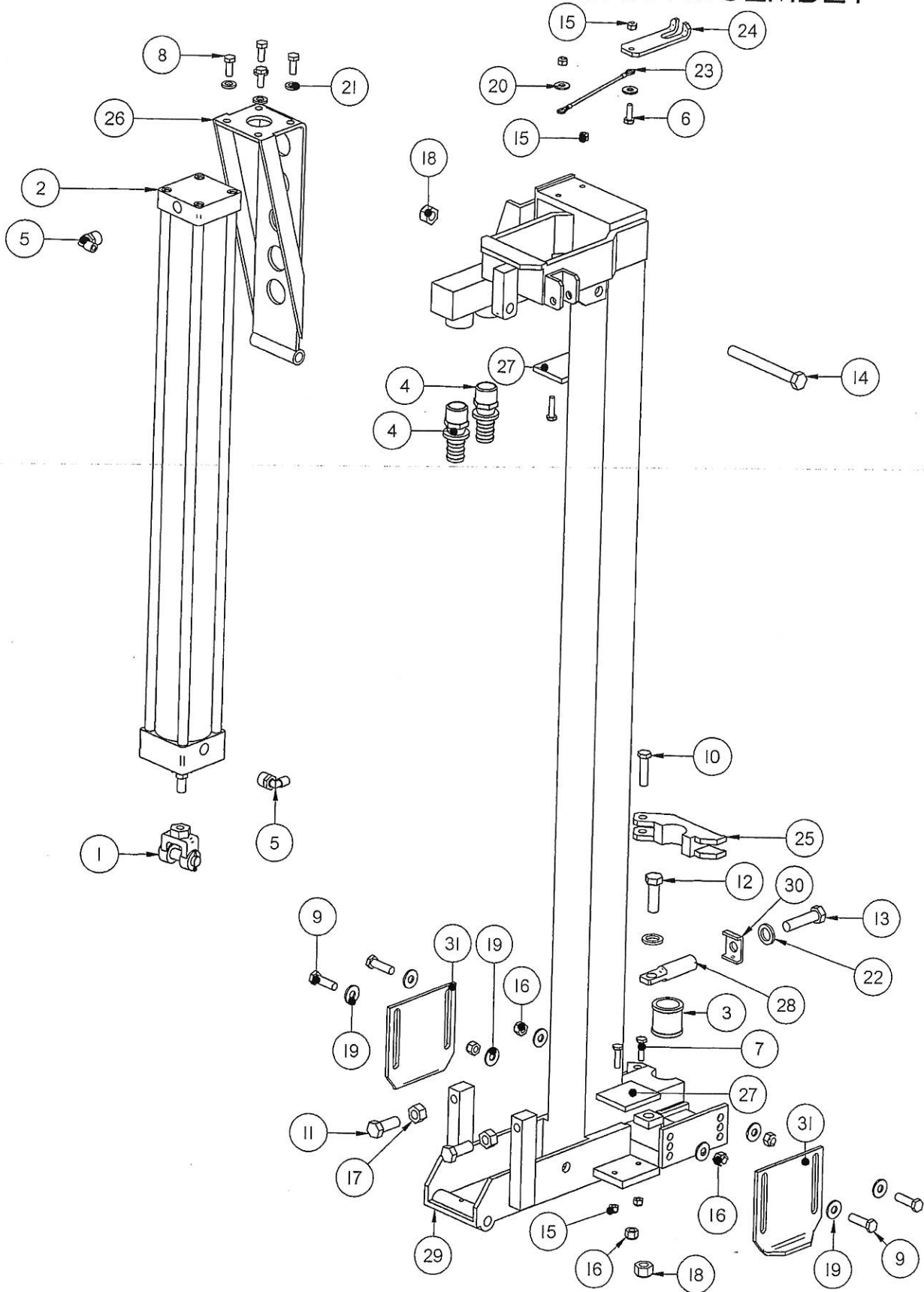

8140IFNG-30

24" DRILL DEPTH FEED BAR ASSEMBLY

Item Number	File Name	Quantity	Description
1	0501cyl.asm	1	CLEVIS WITH PIN FOR 5/8" ROD
2	05161CYL.asm	1	FEED CYLINDER FOR 24" DRILL DEPTH
3	1112mcp.par	1	1 1/8" BUSHING
4	1999fit.par	2	3/4" X 3/4" HOSE SWIVEL
5	2052fit.par	2	1/4" TO 3/8" 90 DEG. FITTING
6	2501blt.par	1	1/4" X 3/4" BOLT
7	2503blt.par	4	1/4" X 1" BOLT
8	2516blt.par	4	5/16" X 3/4" FINE THREAD BOLT
9	2540blt.par	4	3/8" X 1 1/4" BOLT
10	2541blt.par	1	3/8" X 1 1/2" BOLT
11	2560blt.par	2	1/2" X 1 1/4" BOLT
12	2562blt.par	1	1/2" X 1 1/2" BOLT
13	2563blt.par	1	1/2" X 2" BOLT
14	2572blt.par	1	1/2" X 4 1/2" BOLT
15	2716nut.par	5	1/4" NYLON LOCK NUT
16	2727nut.par	5	3/8" LOCKNUT
17	2732nut.par	2	1/2" STANDARD NUT
18	2734nut.par	2	1/2" LOCKNUT
19	2800was.par	8	5/16" FLAT WASHER
20	2801was.par	2	1/4" FLAT WASHER
21	2821was.par	4	3/8" LOCK WASHER
22	2831was.par	2	7/8"OD X 1/2"ID WASHER 10GA.
23	3030pin.par	1	6" LANYARD WITH LOOPS
24	cra0218.par	1	CARRIAGE LOCK
25	mfa0609.par	1	BIT GUIDE
26	mfa06243.par	1	CYLINDER MOUNTING BRACKET (24" DD)
27	mfa0626.par	2	STOP PAD
28	mfa0674.par	1	SWIVEL BOLT
29	mfa06860.par	1	FEED BAR 24" DRILL DEPTH
30	mfa0690.par	1	BIT GUIDE KEEPER
31	mob0917.par	2	AUTO ALIGN STOP

24" DRILL DEPTH CARRIAGE ASSEMBLY

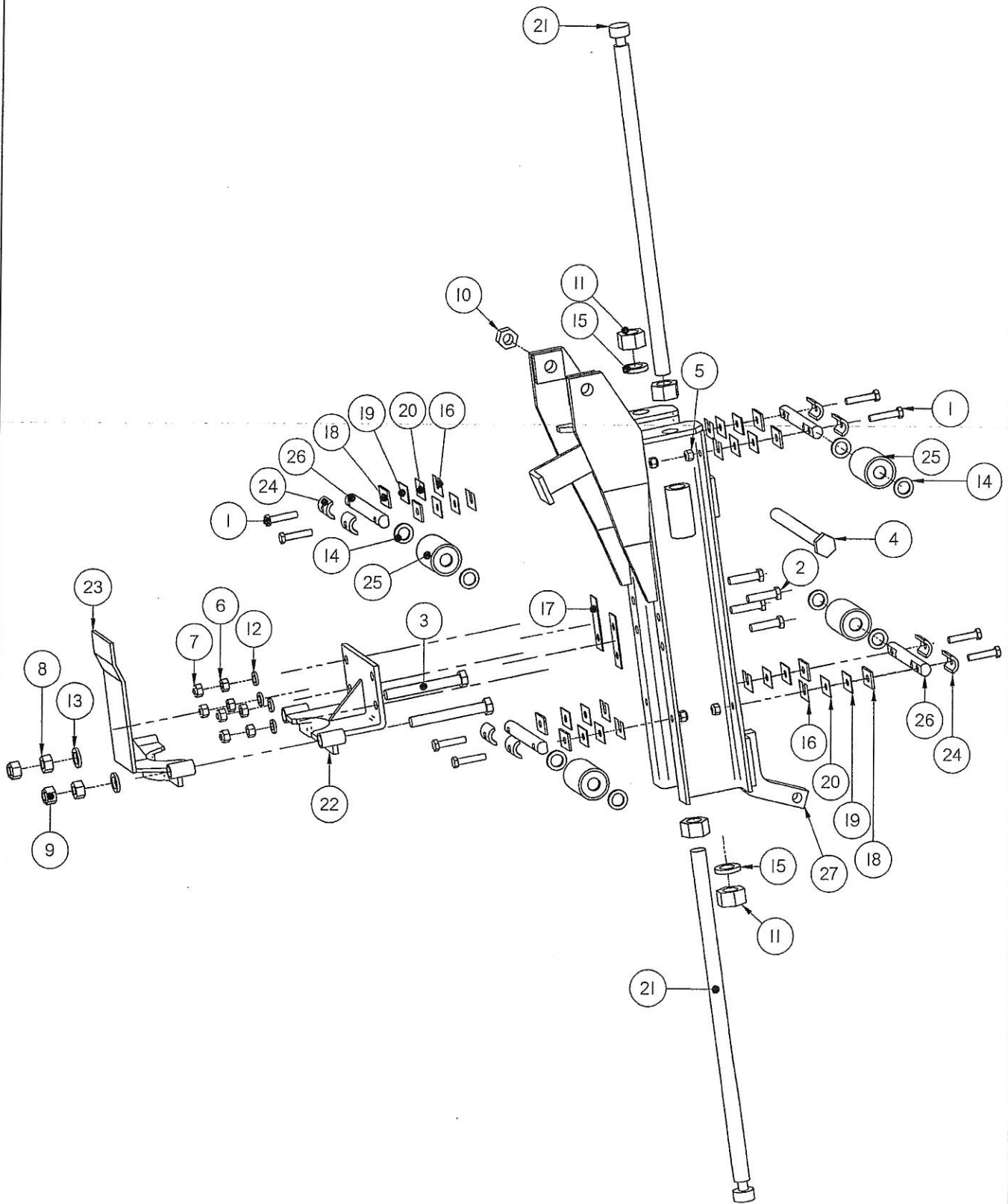

8140IFNG-50

24" DRILL DEPTH CARRIAGE ASSEMBLY

Item Number	File Name	Quantity	Description
1	2526BLT.par	8	5/16" X 1 1/2" BOLT
2	2541BLT.par	4	3/8" X 1 1/2" BOLT
3	2570BLT.par	2	1/2" X 4" BOLT
4	2590BLT.par	1	5/8" X 8" BOLT
5	2719NUT.par	8	5/16" NYLON LOCK NUT
6	2725NUT.par	4	3/8" STANDARD NUT
7	2727NUT.par	4	3/8" LOCKNUT
8	2732NUT.par	2	1/2" STANDARD NUT
9	2734NUT.par	2	1/2" LOCKNUT
10	2742NUT.par	1	5/8" LOCKNUT
11	27490NUT.par	4	3/4" COIL ROD NUT
12	2821WAS.par	4	3/8" LOCK WASHER
13	2832WAS.par	2	1/2" LOCK WASHER
14	2841WAS.par	8	5/16" WASHER
15	2852WAS.par	2	3/4" LOCK WASHER
16	7009TAB.par	8	STAINLESS STEEL SHIM (AS NEEDED)
17	7010TAB.par	2	16 GA. TWO HOLE SHIM
18	7011TAB.par	8	12 GA. SHIM (AS NEEDED)
19	7012TAB.par	8	18 GA. SHIM (AS NEEDED)
20	7013TAB.par	8	22 GA. SHIM (AS NEEDED)
21	Cra02030.Par	2	18" STOP ROD
22	CRA0214.par	1	UPPER DRILL BRACKET
23	CRA0216.par	1	LOWER DRILL BRACKET
24	CRA0230.par	8	BEARING KEEPER
25	CRA0233.par	4	ROLLER BEARING DRUM
26	CRA0234.par	4	ROLLER BEARING AXLE
27	CRG01041.par	1	CARRIAGE

8140IFNG-60

24" DRILL DEPTH MAST ASSEMBLY

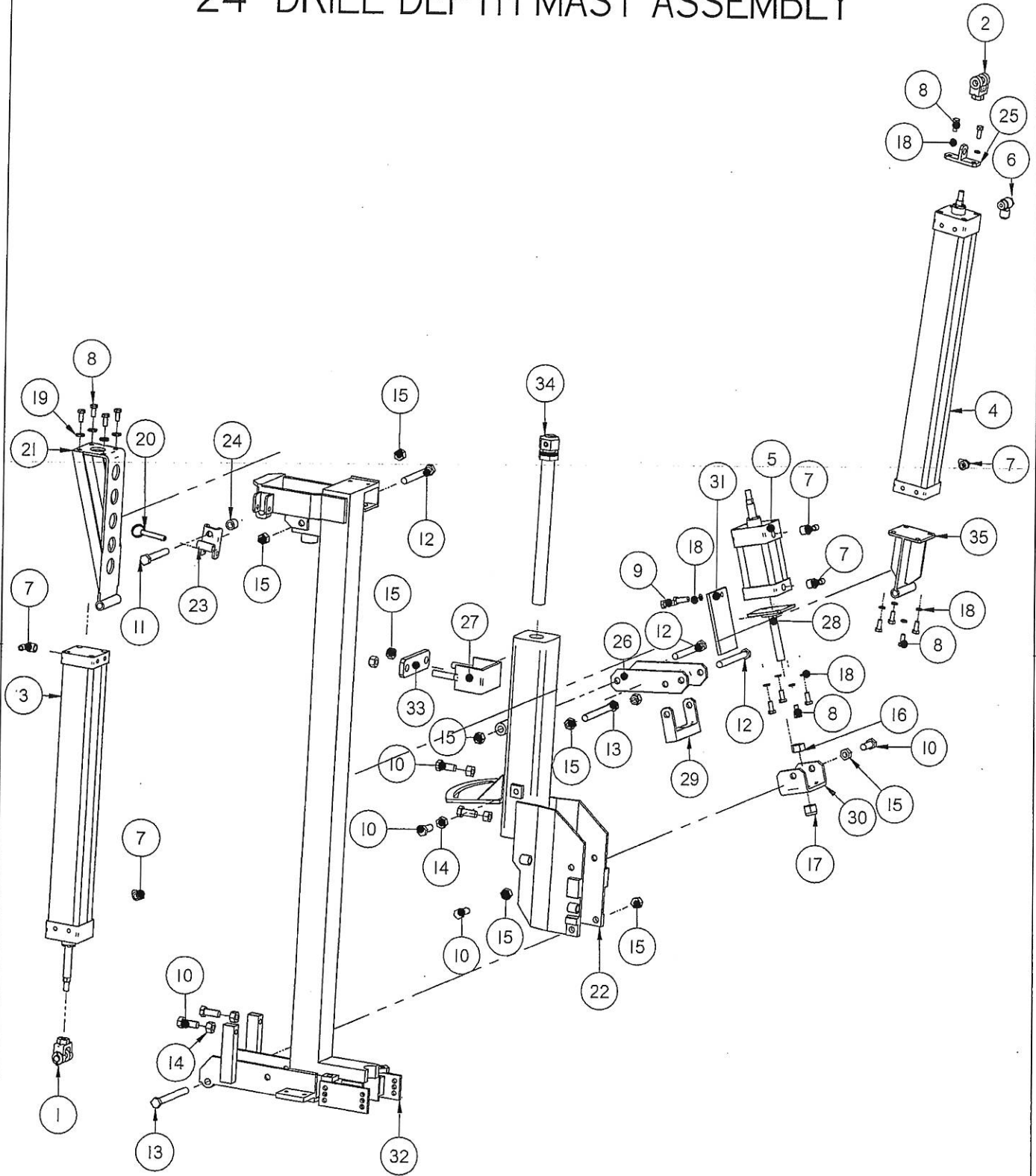

8140IFNG-70

24" DRILL DEPTH MAST ASSEMBLY

Item Number	File Name	Quantity	Description
1	0501cyl.asm	1	CLEVIS WITH PIN FOR 5/8" ROD
2	0501cyl.par	1	CYLINDER CLEVIS
3	0514ICYL.asm	1	2.5" X 20" FEED CYLINDER
4	0514ICYL.asm	1	2.5" X 20" FEED CYLINDER
5	05210ICYL.asm	1	2 1/2" X 2" CYLINDER
6	0611val.par	1	FLOW CONTROL VALVE
7	2052fit.par	5	1/4" TO 3/8" 90 DEG. FITTING
8	2516blt.par	14	5/16" X 3/4" FINE THREAD BOLT
9	2538blt.par	2	3/8" X 1" BOLT
10	2560blt.par	7	1/2" X 1 1/4" BOLT
11	2568blt.par	1	1/2" X 3 1/2" BOLT
12	2572blt.par	3	1/2" X 4 1/2" BOLT
13	2575blt.par	2	1/2" X 5" BOLT
14	2732nut.par	5	1/2" STANDARD NUT
15	2734nut.par	10	1/2" LOCKNUT
16	2740nut.par	1	5/8" STANDARD NUT
17	2743nut.par	1	5/8" NYLON LOCK NUT
18	2810was.par	12	5/16" LOCK WASHER
19	2821was.par	4	3/8" LOCK WASHER
20	3029pin.par	1	LOCK PIN
21	mfa06243.par	1	CYLINDER MOUNTING BRACKET (24" DDI)
22	mfa06500.par	1	MAST WITH SKEW ADJUST 210 SRA
23	mfa0672.par	1	CYLINDER LOCK CLEVIS 4 WAY
24	mfa06721.par	1	CYLINDER LOCK CLEVIS SPACER
25	mfa0673.par	1	CYLINDER LOCK
26	mfa0678.par	1	ALIGNMENT ARM
27	mfa0680.par	1	VERTICAL ADJUSTING BRACKET
28	mfa0682.par	1	CYLINDER ADJUST AUTO ALIGN
29	mfa0683.par	1	AUTO ALIGN CLEVIS
30	mfa0684.par	1	PIVOT AUTO ALIGN
31	mfa06840.par	1	RETAINING PLATE FOR AUTO ALIGN CYLINDER
32	mfa06860.par	1	FEED BAR 24" DRILL DEPTH
33	mfa0689.par	1	VERTICAL ADJUSTMENT CLAMP STRAP
34	srul30l.asm	1	SCREW JACK ASSEMBLY
35	srul324.par	1	CYLINDER MOUNT

8140IFNG-80

4 WAY MAIN FRAME ASSEMBLY

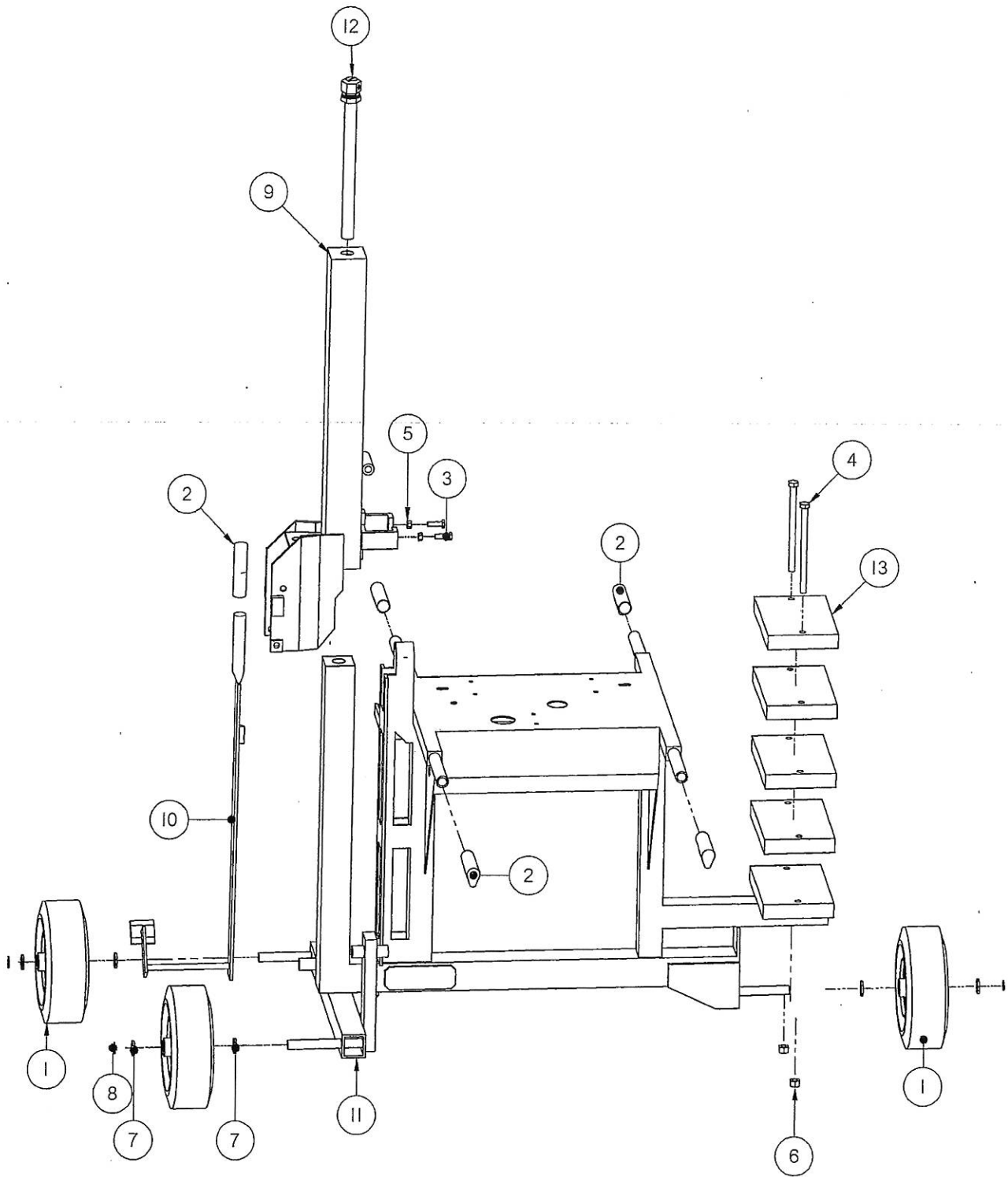

814050FNG-10

4 WAY MAIN FRAME ASSEMBLY

Item Number	File Name	Quantity	Description
1	0202WHL.asm	3	REAR WHEEL
2	1820GRO.par	5	HANDLE GRIP
3*	2540BLT.par	2	3/8" X 1 1/4" BOLT
4	2580BLT.par	2	1/2" X 7 1/2" BOLT
5	2725NUT.par	2	3/8" STANDARD NUT
6	2734NUT.par	2	1/2" LOCKNUT
7*	2851WAS.par	6	3/4" X 10 GA. WASHER
8*	3036PIN.par	3	SNAP RING
9	MFA06501.par	1	4 WAY MAST
10*	MFA0651.par	1	HAND BRAKE
11	MNF0517.par	1	4 WAY FRAME
12	SRUI301.asm	1	SCREW JACK ASSEMBLY
13	SRUI3059.par	4	COUNTER WEIGHT

814050FNG-20

4 WAY FEED BAR ASSEMBLY

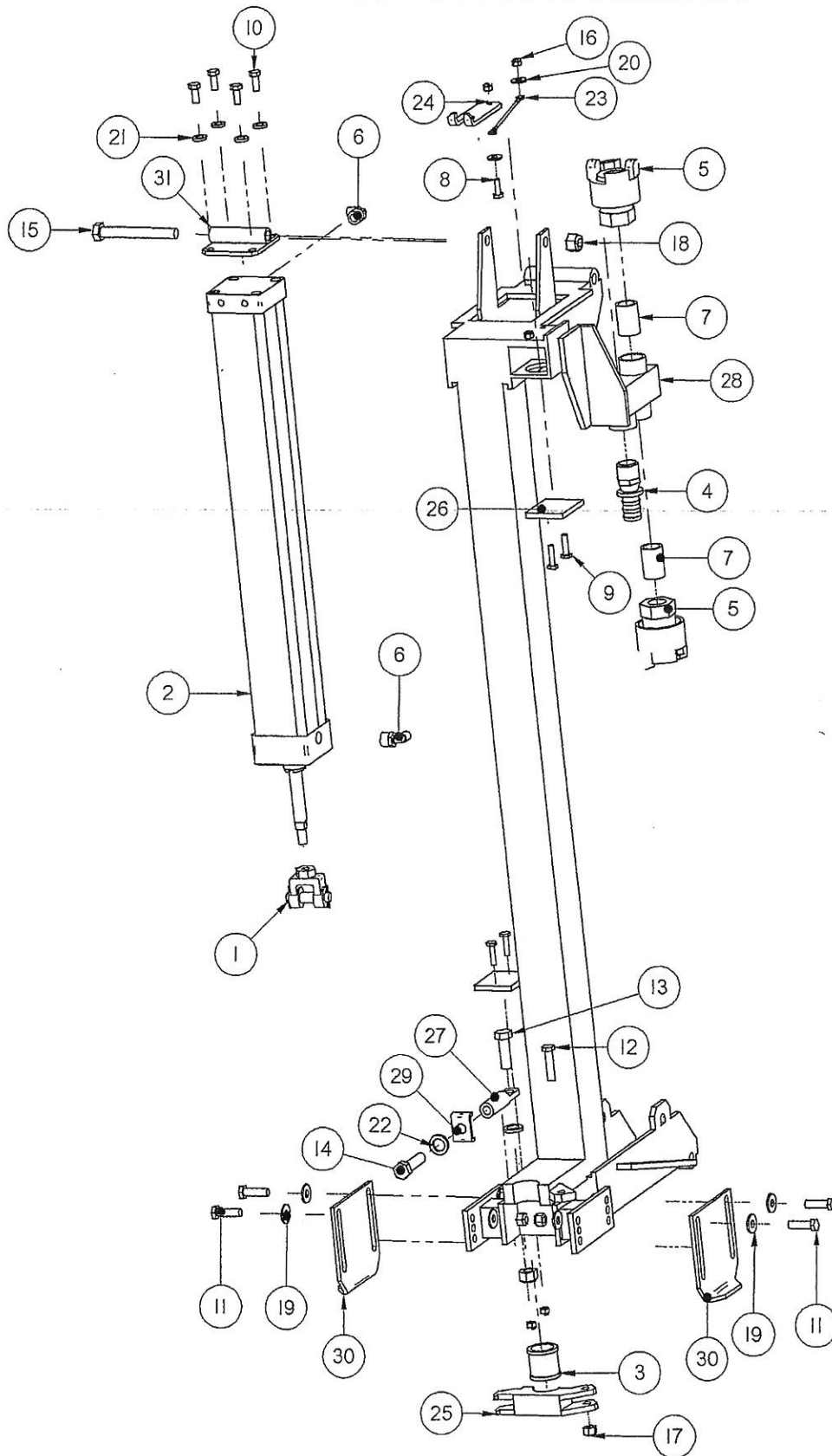

814050FNG-30

4 WAY FEED BAR ASSEMBLY

Item Number	File Name	Quantity	Description
1	0501cyl.asm	1	CLEVIS WITH PIN FOR 5/8" ROD
2	0514ICYL.asm	1	2.5" X 20" FEED CYLINDER
3	1112mcp.par	1	1 1/8" BUSHING
4	1999fit.par	1	3/4" X 3/4" HOSE SWIVEL
5	20090fit.asm	2	3/4" AUTO LOCKING QUICK COUPLING
6*	2052fit.par	2	1/4" TO 3/8" 90 DEG. FITTING
7	2114pft.par	2	3/4" X 1 1/2" NIPPLE
8	2501blt.par	1	1/4" X 3/4" BOLT
9	2503blt.par	4	1/4" X 1" BOLT
10	2516blt.par	4	5/16" X 3/4" FINE THREAD BOLT
11	2540blt.par	4	3/8" X 1 1/4" BOLT
12	2541blt.par	1	3/8" X 1 1/2" BOLT
13	2562blt.par	1	1/2" X 1 1/2" BOLT
14*	2563blt.par	1	1/2" X 2" BOLT
15	2570blt.par	1	1/2" X 4" BOLT
16*	2716nut.par	5	1/4" NYLON LOCK NUT
17	2727nut.par	5	3/8" LOCKNUT
18	2734nut.par	2	1/2" LOCKNUT
19	2800was.par	8	5/16" FLAT WASHER
20	2801was.par	2	1/4" FLAT WASHER
21	2821was.par	4	3/8" LOCK WASHER
22	2831was.par	2	7/8"OD X 1/2"ID WASHER 10GA.
23	3030pin.par	1	6" LANYARD WITH LOOPS
24	cra0218.par	1	CARRIAGE LOCK
25	mfa0609.par	1	BIT GUIDE
26*	mfa0626.par	2	STOP PAD
27*	mfa0674.par	1	SWIVEL BOLT
28	mfa06850.par	1	24" DRILL DEPTH FEED BAR
29*	mfa0690.par	1	BIT GUIDE KEEPER
30	mob0917.par	2	AUTO ALIGN STOP
31	srg1120.par	1	CYLINDER MOUNT BRACKET

4 WAY SRA CARRIAGE ASSEMBLY

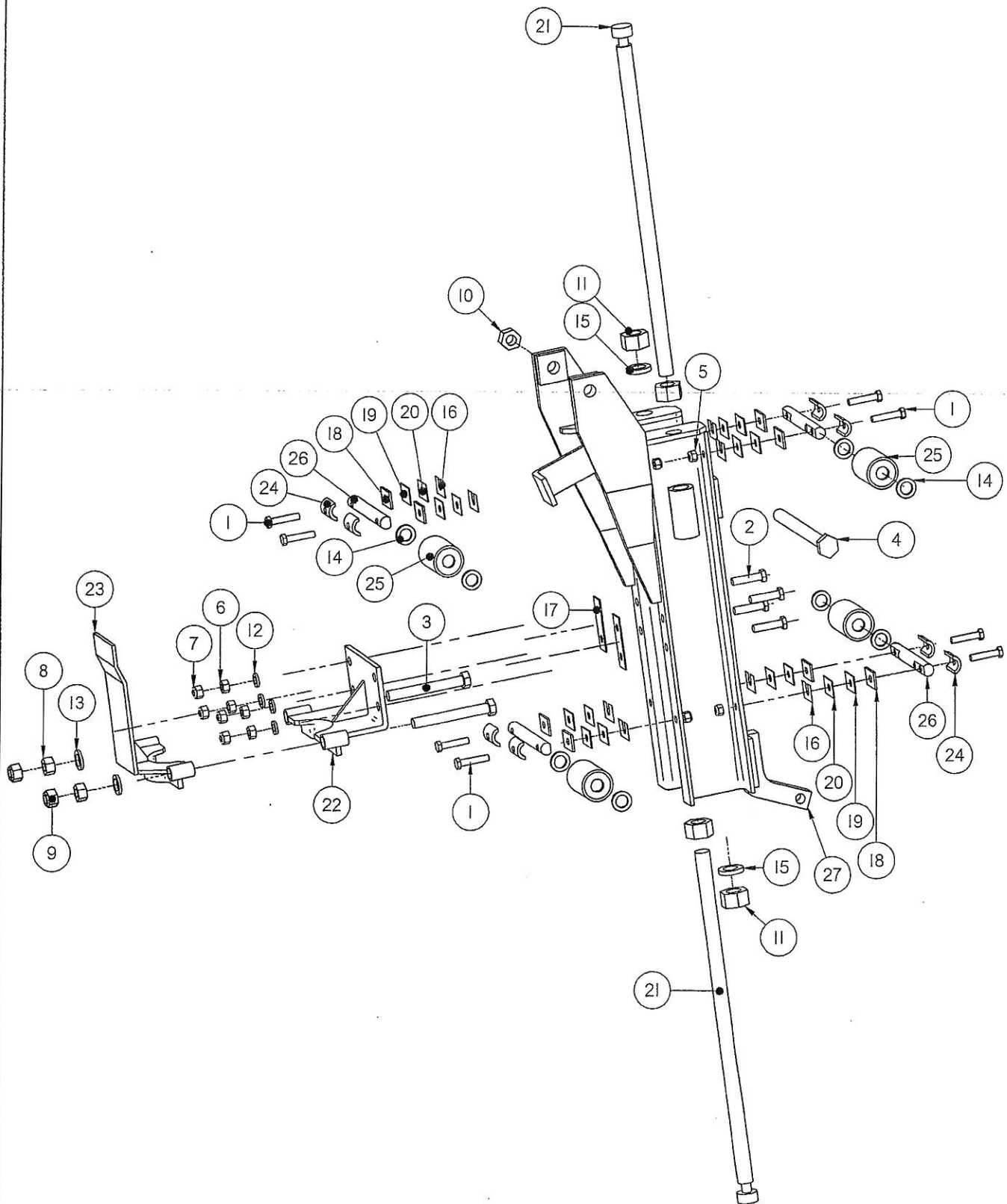

814050FNG-50

4 WAY SRA CARRIAGE ASSEMBLY

Item Number	File Name	Quantity	Description
1	2526BLT.par	8	5/16" X 1 1/2" BOLT
2	2541BLT.par	4	3/8" X 1 1/2" BOLT
3	2570BLT.par	2	1/2" X 4" BOLT
4	2590BLT.par	1	5/8" X 8" BOLT
5	2719NUT.par	8	5/16" NYLON LOCK NUT
6	2725NUT.par	4	3/8" STANDARD NUT
7	2727NUT.par	4	3/8" LOCKNUT
8	2732NUT.par	2	1/2" STANDARD NUT
9	2734NUT.par	2	1/2" LOCKNUT
10	2742NUT.par	1	5/8" LOCKNUT
11	2749NUT.par	4	3/4" COIL ROD NUT
12	2821WAS.par	4	3/8" LOCK WASHER
13	2832WAS.par	2	1/2" LOCK WASHER
14	2841WAS.par	8	5/16" WASHER
15	2852WAS.par	2	3/4" LOCK WASHER
16	7009TAB.par	8	STAINLESS STEEL SHIM (AS NEEDED)
17	7010TAB.par	2	16 GA. TWO HOLE SHIM
18	7011TAB.par	8	12 GA. SHIM (AS NEEDED)
19	7012TAB.par	8	18 GA. SHIM (AS NEEDED)
20	7013TAB.par	8	22 GA. SHIM (AS NEEDED)
21	Cra02030.Par	2	18" STOP ROD
22	CRA0214.par	1	UPPER DRILL BRACKET
23	CRA0216.par	1	LOWER DRILL BRACKET
24	CRA0230.par	8	BEARING KEEPER
25	CRA0233.par	4	ROLLER BEARING DRUM
26	CRA0234.par	4	ROLLER BEARING AXLE
27	CRG01041.par	1	CARRIAGE

814050FNG-60

4 WAY MAST ASSEMBLY

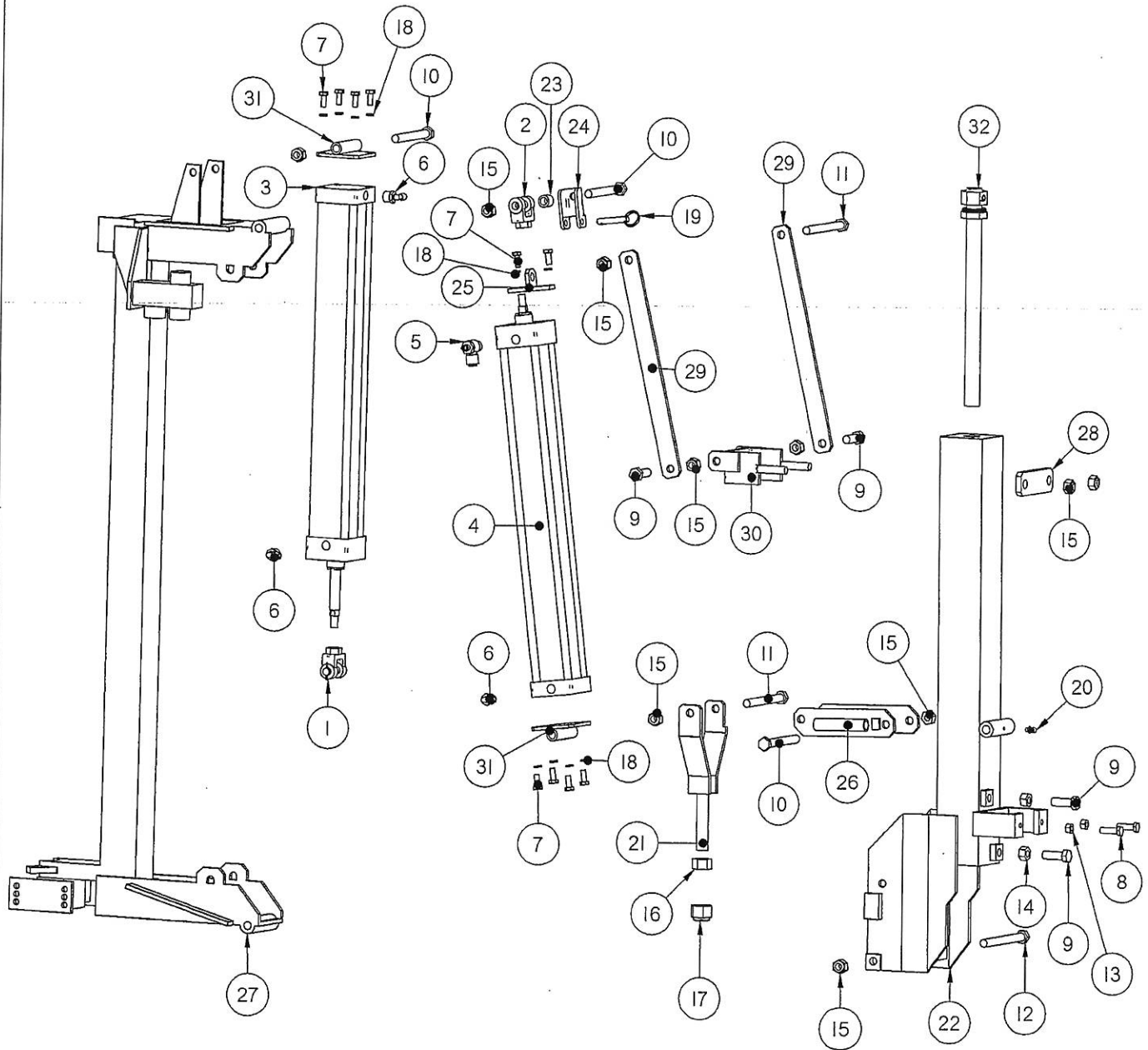

814050FNG-70

4 WAY MAST ASSEMBLY

Item Number	File Name	Quantity	Description
1	0501cyl.asm	1	CLEVIS WITH PIN FOR 5/8" ROD
2	0501cyl.par	1	CYLINDER CLEVIS
3	05141CYL.asm	1	2.5" X 20" FEED CYLINDER
4*	05141CYL.asm	1	2.5" X 20" FEED CYLINDER
5	0611val.par	1	FLOW CONTROL VALVE
6	2052fit.par	3	1/4" TO 3/8" 90 DEG. FITTING
7	2516blt.par	10	5/16" X 3/4" FINE THREAD BOLT
8	2540blt.par	2	3/8" X 1 1/4" BOLT
9	2562blt.par	5	1/2" X 1 1/2" BOLT
10	2572blt.par	3	1/2" X 4 1/2" BOLT
11	2575blt.par	2	1/2" X 5" BOLT
12	2576blt.par	1	1/2" X 5 1/2" BOLT
13	2725nut.par	2	3/8" STANDARD NUT
14	2732nut.par	3	1/2" STANDARD NUT
15	2734nut.par	10	1/2" LOCKNUT
16	2748nut.par	1	3/4" STANDARD NUT
17	2749nut.par	1	3/4" NYLON LOCK NUT
18	2810was.par	10	5/16" LOCK WASHER
19	3029pin.par	1	LOCK PIN
20	95010mis.par	1	90 DEG. GREASE ZERT
21*	mfa0647.par	1	210 SR YOKE
22	mfa0650l.par	1	4 WAY MAST
23	mfa0672l.par	1	CYLINDER LOCK CLEVIS SPACER
24	mfa06722.par	1	CYLINDER LOCK CLEVIS 4 WAY
25*	mfa0673.par	1	CYLINDER LOCK
26*	mfa0678.par	1	ALIGNMENT ARM
27	mfa06850.par	1	24" DRILL DEPTH FEED BAR
28	mfa0689.par	1	VERTICAL ADJUSTMENT CLAMP STRAP
29	mfa0702l.par	2	SUPPORT STRAP
30*	mfa07022.par	1	VERTICAL ADJUSTING BRACKET 4 WAY
31	srg1120.par	2	CYLINDER MOUNT BRACKET
32	srul30l.asm	1	SCREW JACK ASSEMBLY

814050FNG-80

ATTACHMENT FITTINGS FOR THE 4 WAY

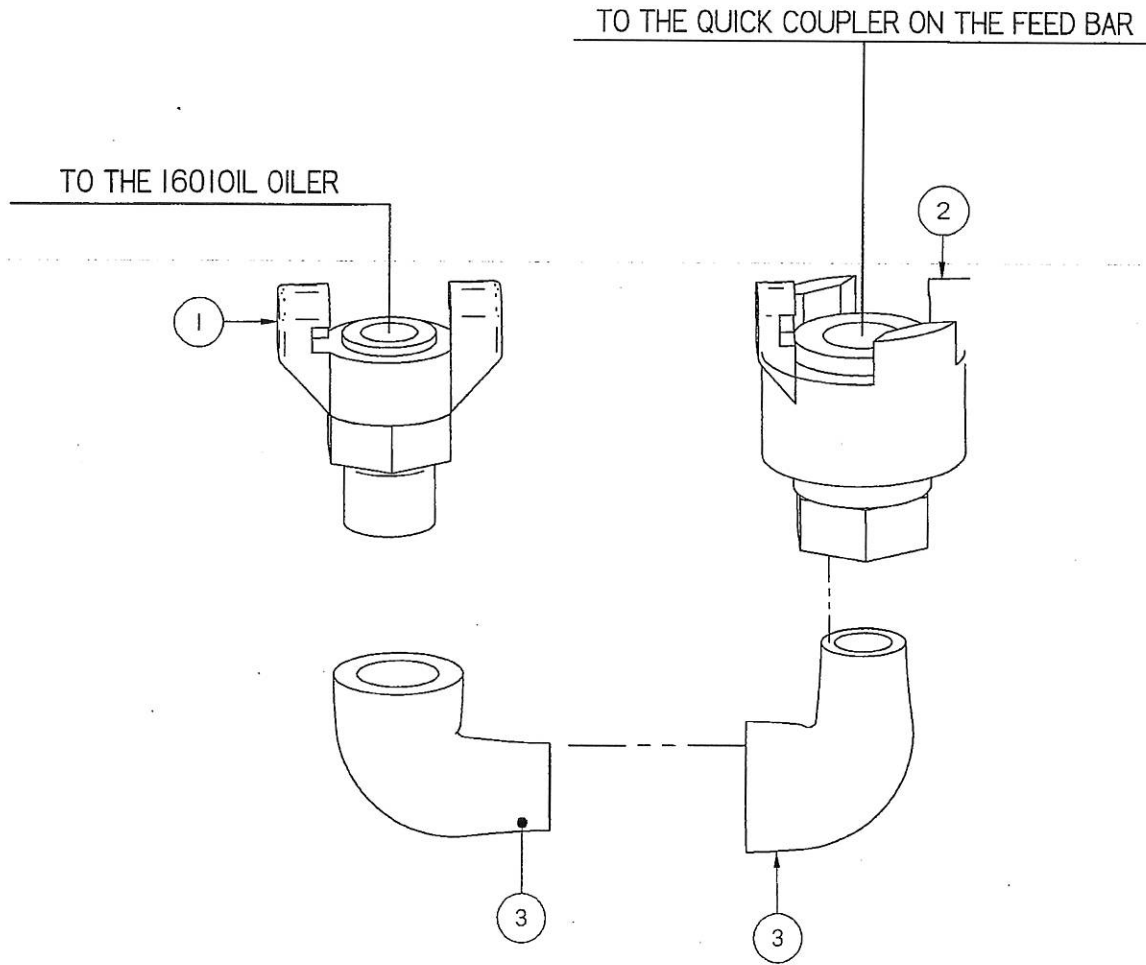

Item Number	File Name	Quantity	Description
1	2006FIT.par	1	3/4" MALE PIPE TO QUICK COUPLER
2	20090FIT.asm	1	3/4" AUTO LOCKING QUICK COUPLING
3	2155PFT.par	2	3/4" STREET ELL

814050FNG-90

4 WAY FEED BAR SCHEMATIC

HOSE TO THE 1601OIL
WHILE IN THE ON GRADE POSITION

FEED CYLINDER EXTEND
1903HOS 1/4" BLACK TUBE FROM THE
060102VAL ON THE CONTROL PANEL

1904HOS TO THE DRILL MOTOR

TO THE 1601OIL ON THE MAIN FRAME
INSERT PLUG WHILE IN THE ON GRADE POSITION

FEED CYLINDER RETRACT
1903HOS 1/4" BLACK TUBE FROM THE
0809REG ON THE CONTROL PANEL

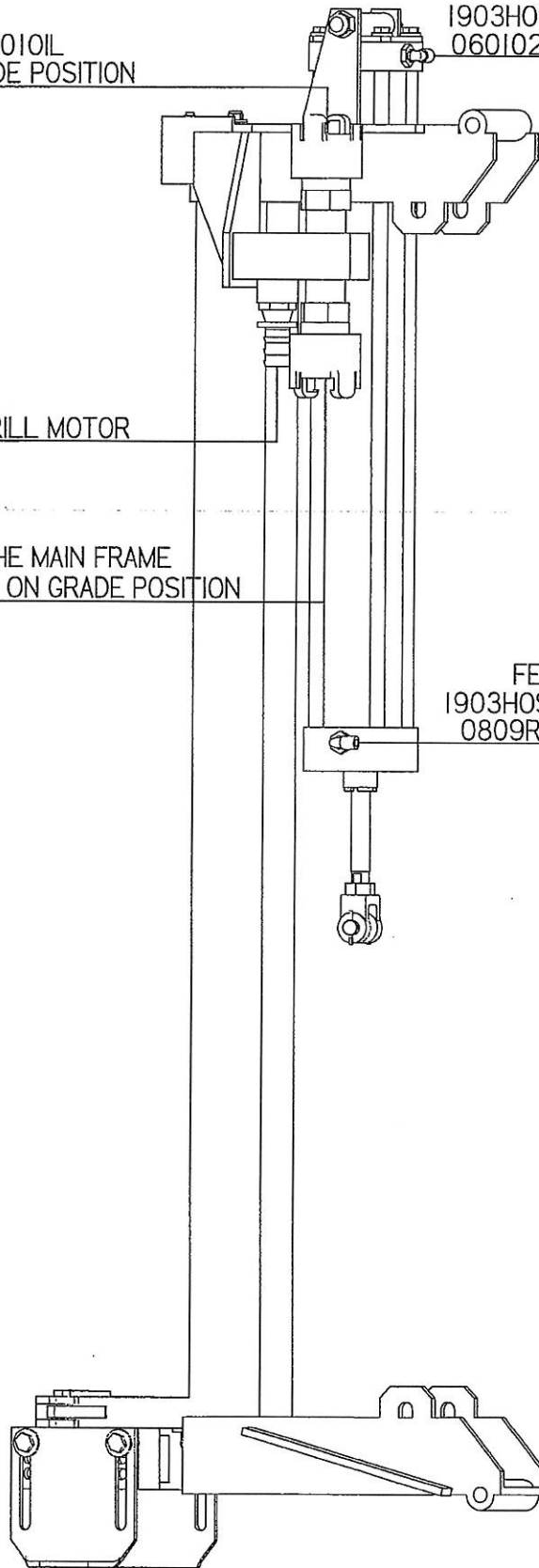

814050FNG-100

GUIDE WHEEL ASSEMBLY --- 4 WAY

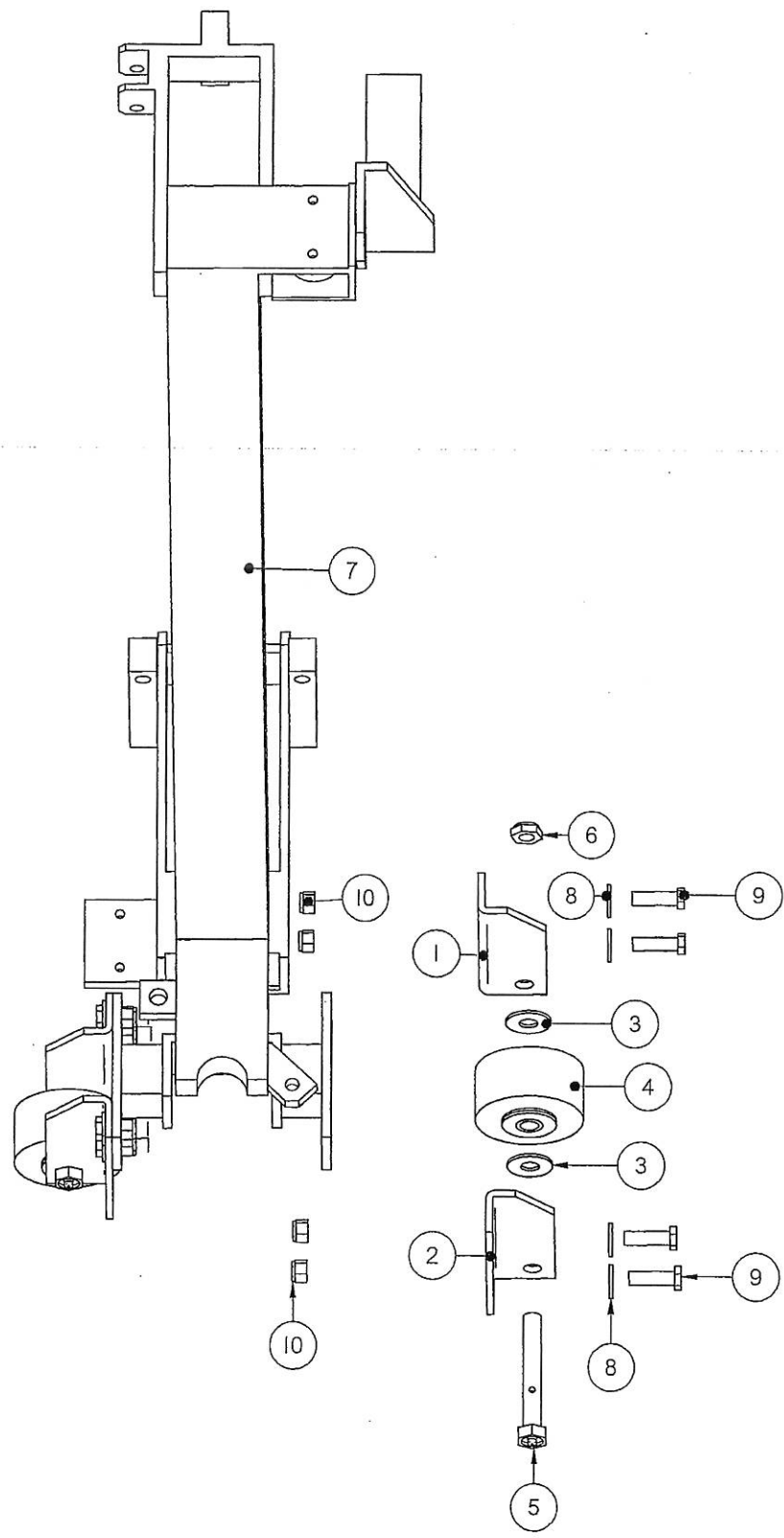

814050FNG-110

GUIDE WHEEL ASSEMBLY — 4 WAY

Item Number	File Name	Quantity	Description
1*	MOB0928.par	2	GUIDE WHEEL BRACKET RIGHT SRA
2*	MOB0929.par	2	GUIDE WHEEL BRACKET LEFT SRA
3	2830WAS.par	2	1/2" WASHER
4*	0207WHL.asm	2	GUIDE WHEEL
5	25675BLT.par	2	GREASE BOLT
6	25675BLT.par	1	GREASE BOLT NUT
7*	MFA0686.par	1	FEED BAR
8	2800WAS.par	7	5/16" FLAT WASHER
9	2540BLT.par	8	3/8" X 1 1/4" BOLT
10	2727NUT.par	8	3/8" LOCKNUT

814050FNG-120

210B-SRA QMP VACUUM SYSTEM ASSEMBLY - PAGE 01

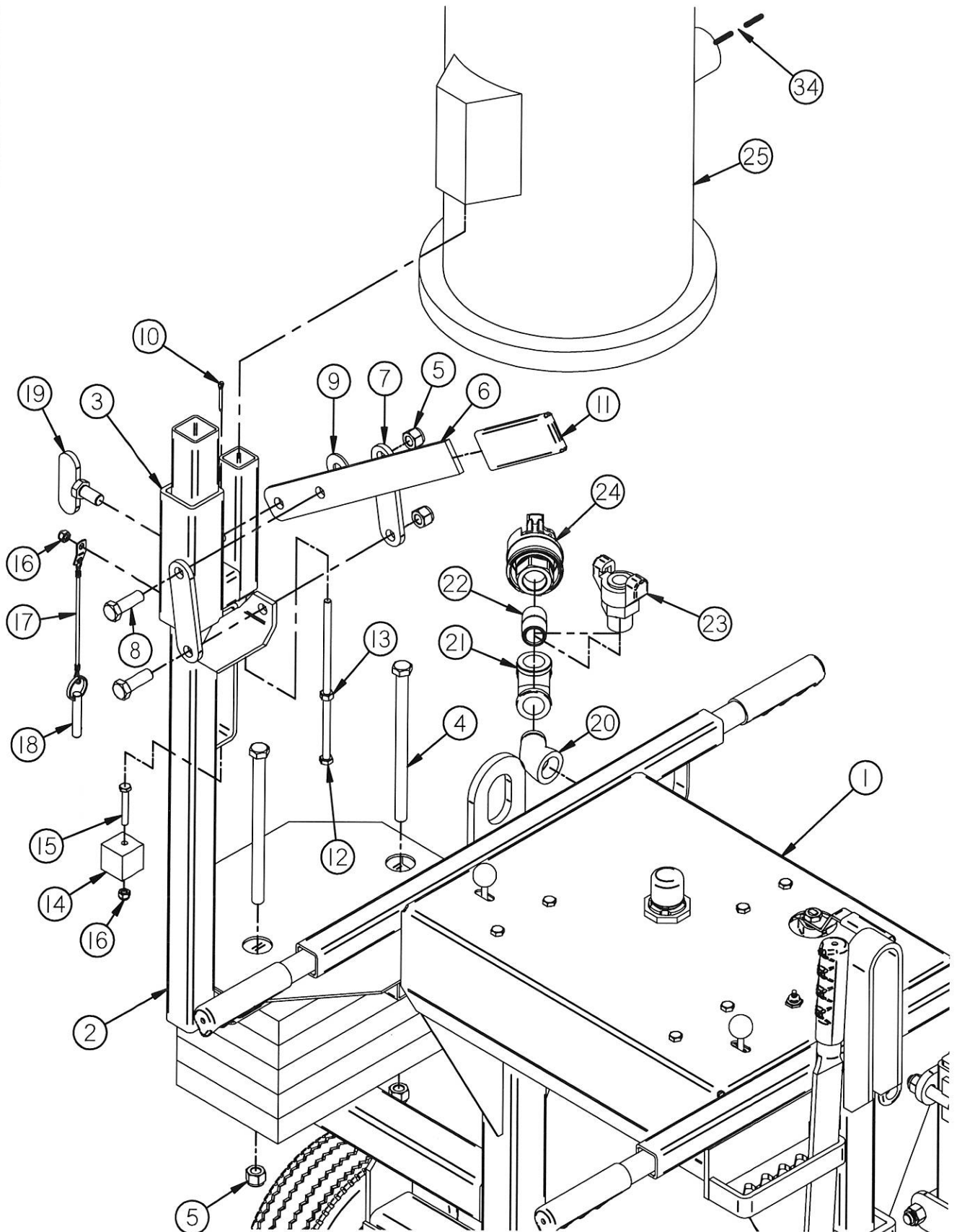

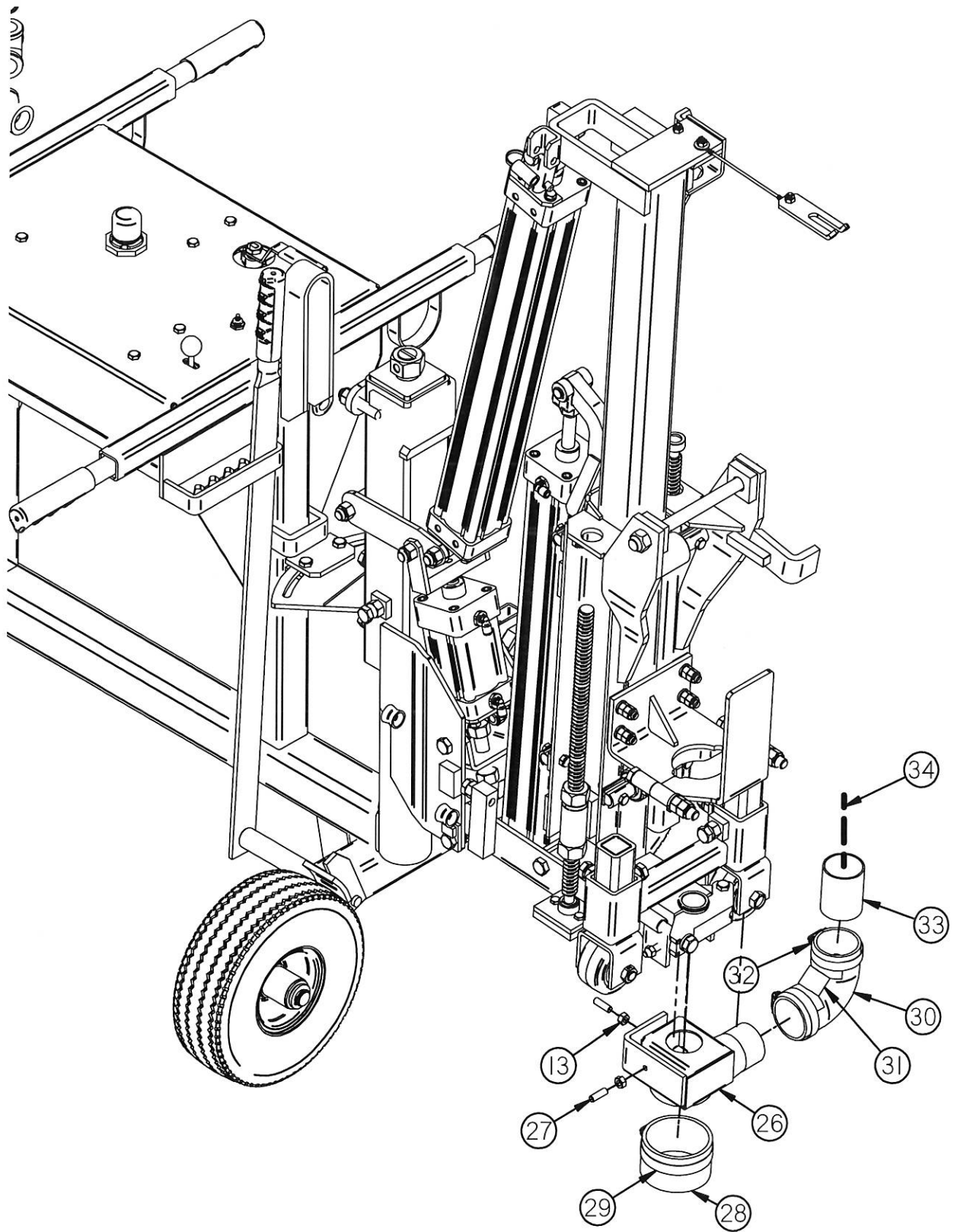

210B-SRA QMP VACUUM SYSTEM ASSEMBLY - PAGE 03

Item No.	Part No.	Quantity	Description
1	81406FNG	1	210B SRA DRILL
2	MFA069931Q	1	DUST COLLECTION FRAME 210B
3	MFA069902Q	1	ADAPTER - LIFTING BALE - DUST COLLECTION
4	2580BLT	2	1/2" NC X 7.50" HX HD BOLT
5	2734NUT	4	1/2" NC NYLON INSERT LOCKNUT
6	MFA069904_01	1	RAISE/LOWER LEVER - DUST COLLECTION
7	MFA069906	2	FRAME CLAMP LONG
8	2562 BLT	2	1/2" NC X 1.50" HX HD TAP BOLT
9	2830 WAS	1	1/2" STD. FLAT WASHER
10	3022I PIN	1	1/8" X 1-1/4" COTTER PIN
11	18206GR0	1	LEVER GRIP
12	2536 BLT	1	5/16" NC X 8.00" HX HD BOLT
13	2717 NUT	3	5/16 UNC HEX NUT (ZP, GR. 5)
14	MFA069902Q_02	1	BOLT ON BLOCK
15	25072 BLT	1	1/4" NC X 1.75" HX HD BOLT
16	2716NUT	2	1/4" NC NYLON LOCK NUT
17	3031PIN	1	LANYARD W/TAB ONE END
18	3029PIN	1	LOCK PIN
19	MFA069903	1	SET SCREW - DUST COLLECTION
20	2148PFT	1	3/4" 45 DEG. STREET ELL
21	2103PFT	1	3/4" PIPE TEE
22	2114PFT	1	3/4" X 1 1/2" NIPPLE
23	2006FIT	1	3/4" MALE PIPE TO QUICK COUPLER
24	20090 FIT	1	COUPLING (3/4" NPT)
25	9695Q MIS	1	MICRO QMP VACUUM
26	MFA069913	1	DUST COLLECTOR HEAD
27	2521 BLT	2	5/16-18 X 1" SET SCREW
28	190406 HOS	1	3" COLLECTOR HOSE (2" LONG PIECE)
29	19503 CLP	1	WORM GEAR HOSE CLAMP (3 - 4")
30	19045 HOS	1	2" 90 DEG. SILICONE HOSE COUPLER
31	MFA069914	1	90 DEG. ELBOW CLAMP
32	195025 CLP	2	WORM GEAR HOSE CLAMP (1-1/2" - 2-1/2")
33	MFA069910_12	1	DUST HEAD ROUND TUBE
34	19255 HOS	1	2" VACUUM HOSE

210B-SRA VACUUM SYSTEM ASSEMBLY - PAGE 01

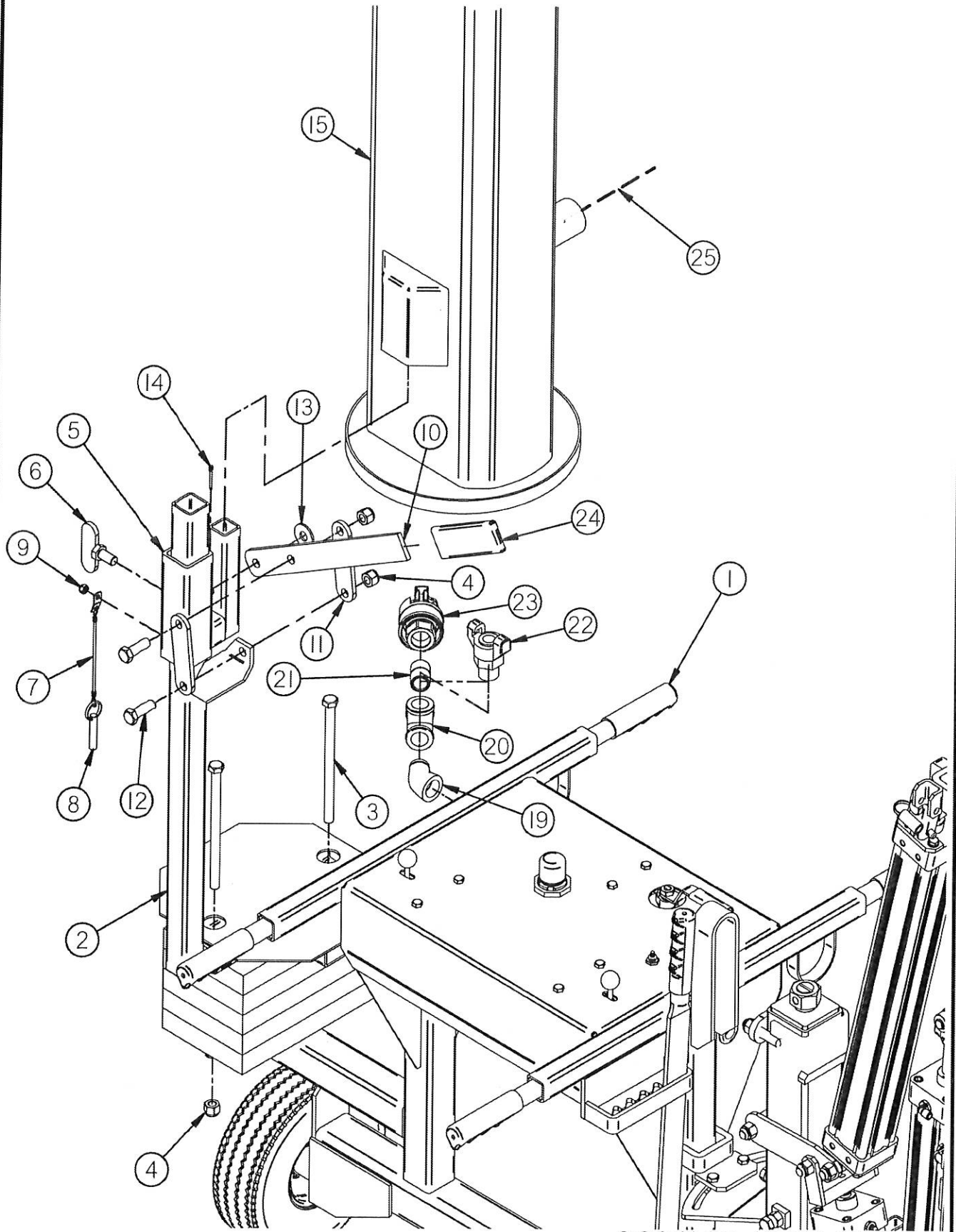

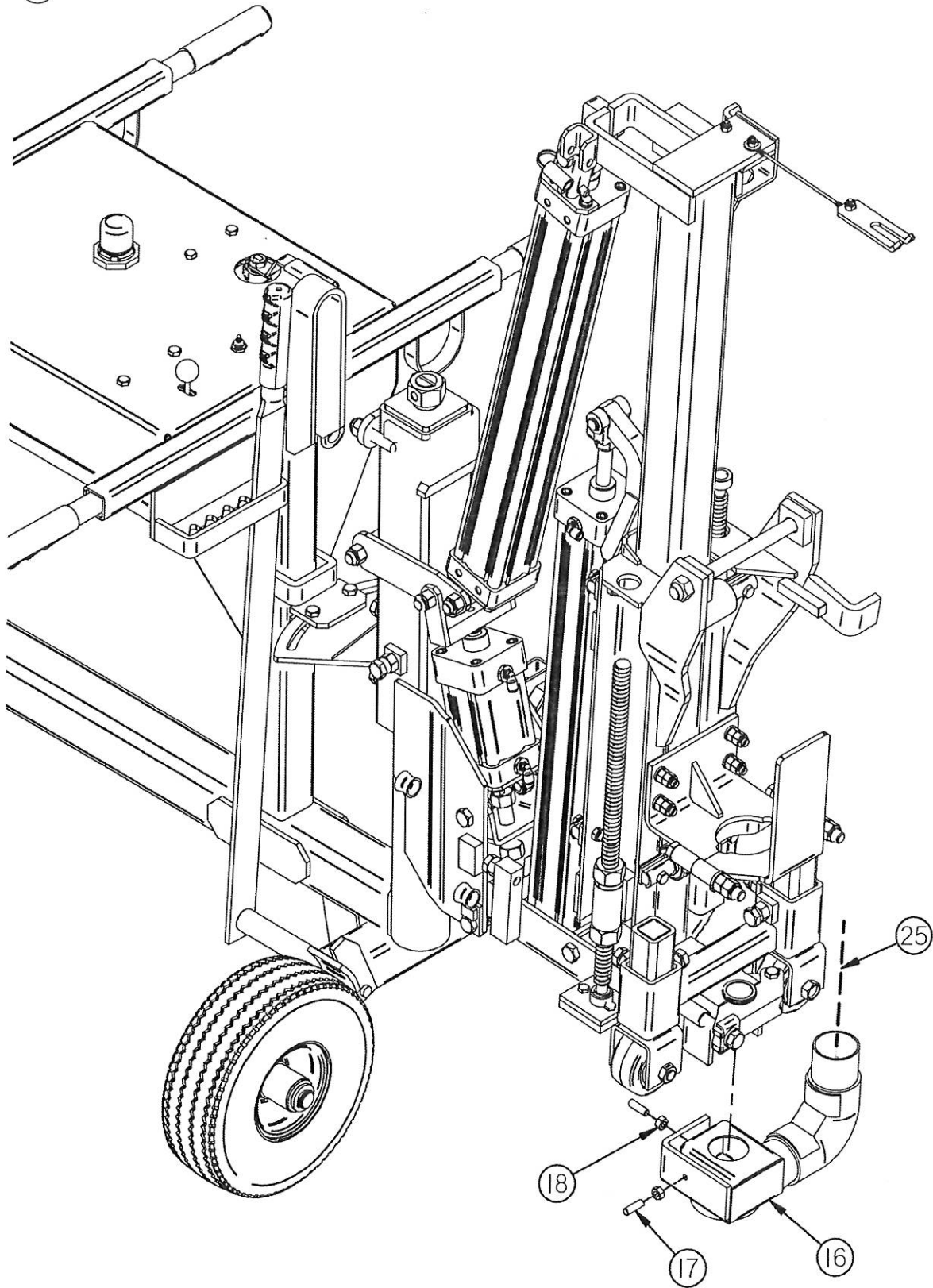

210B-SRA VACUUM SYSTEM ASSEMBLY - PAGE 03

Item No.	Part No.	Quantity	Description
1	81406FNG	1	210B SRA DRILL
2	MFA069931	1	DUST COLLECTION FRAME 210B
3	2580BLT	2	1/2" NC X 7.50" HX HD BOLT
4	2734NUT	4	1/2" NC NYLON INSERT LOCKNUT
5	MFA069902	1	ADAPTER - LIFTING BALE - DUST COLLECTION
6	MFA069903	1	SET SCREW - DUST COLLECTION
7	3031PIN	1	LANYARD W/TAB ONE END
8	3029PIN	1	LOCK PIN
9	2716NUT	1	1/4" NC NYLON LOCK NUT
10	MFA069904	1	RAISE/LOWER LEVER - DUST COLLECTION
11	MFA069906	2	FRAME CLAMP LONG
12	2562 BLT	2	1/2" NC X 1.50" HX HD TAP BOLT
13	2830 WAS	1	1/2" STD. FLAT WASHER
14	30221 PIN	1	1/8" X 1-1/4" COTTER PIN
15	9695MIS	1	MICRO VACUUM
16	MFA069913	1	DUST COLLECTOR HEAD
17	2521 BLT	2	5/16-18 X 1" SET SCREW
18	2717 NUT	2	5/16 UNC HEX NUT (ZP, GR. 5)
19	2148PFT	1	3/4" 45 DEG. STREET ELL
20	2103PFT	1	3/4" PIPE TEE
21	2114PFT	1	3/4" X 1 1/2" NIPPLE
22	2006FIT	1	3/4" MALE PIPE TO QUICK COUPLER
23	20090 FIT	1	COUPLING (3/4" NPT)
24	18206GRO	1	LEVER GRIP
25*	19255 HOS	1	2" VACUUM HOSE

Spare parts list CP 0032 A 7/8" x 3 1/4"

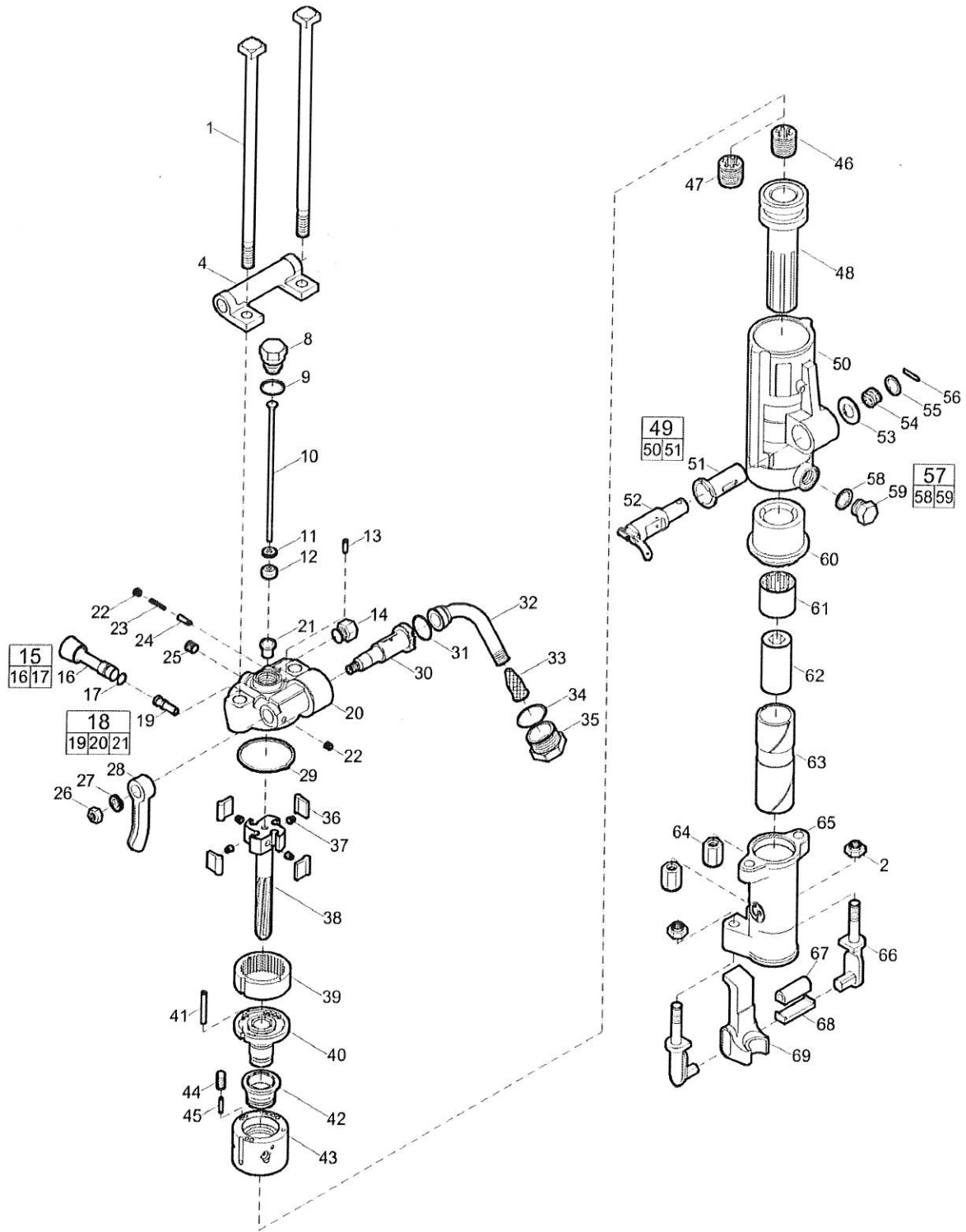

Refer to the Parts Online web page for most up-to-date information. The printed information might be outdated.

Item	Part No.	Name	Qty	L
1	R086623	Bolt - Thru	2	
2	R005742	Nut - Elastic stop	Z	A
4	R086608	Bracket - Handle	1	
8	R076793	Plug - Air tube	1	
9	R000537	Gasket - Tube plug	2	
10	R077184	Tube - Air	1	
11	R075449	Washer - Air tube	1	
12	R075099	Rubber - Air tube	1	
13	R075802	Pin - Valve plunger	1	
14	R076372	Plug - Water valve	1	
15	R079130	Water valve port plug, complete	1	
16	-	Water valve port plug	1	
17	C079489	O-ring	1	
18	R087948	Backhead, complete	1	
19	R098054	Bushing - Water valve	1	
20	-	Backhead	1	
21	R137738	Bushing - Blow tube	1	
22	C068064	Plug - Pipe	2	
23	R085671	Spring - Valve plunger	1	
24	R086627	Plunger - Throttle valve	1	
25	C068799	Plug - pipe, Ø 1/4 in., Ø 6.5 mm	1	C
26	P002149	Nut - Hexagon	1	D
27	C036717	Lockwasher - Head latch	1	E
28	R079124	Handle - Throttle valve	1	
29	H0979432	Gasket	1	
30	R086628	Valve - Throttle	1	
31	P103521	O-ring	1	
32	R075265	Swivel - Air inlet	1	
33	R005584	Screen - Air inlet	1	
34	R110317	O-ring	1	
35	R000530	Air swivel nut	1	
36	R075267	Pawl	4	
37	R086654	Spring - Pawl	4	
38	R086622	Bar - Rifle	1	

Refer to the Parts Online web page for most up-to-date information. The printed information might be outdated.

Item	Part No.	Name	Qty	L
39	R076194	Ring - Ratchet	1	
40	R098085	Bushing - Valve guide	1	
41	R075772	Pin - Valve case dowel	1	
42	R076263	Valve	1	
43	R076264	Case - Valve	1	
44	R098084	Plug - Oil regulating	1	
45	R085625	Stem - Oil regulating	1	
46	R075839	Nut - Rifle bar	1	F
47	R075826	Nut - Rifle bar	1	G
48	R000088	Piston	1	
49	R087990	Cylinder, complete	1	
50	--	Cylinder	1	
51	R086611	Bushing - Blower valve	1	
52	R086612	Valve - Blower	1	
53	R075777	Washer - Blower valve	1	
54	R075778	Spring - Blower valve	1	
55	R075780	Washer - Valve spring	1	
56	R076266	Pin - Spring	1	
57	R085611	Oil plug, complete	1	
58	R091176	Gasket - Oil plug	1	
59	--	Oil plug	1	
60	R042161	Bushing - Cylinder	1	
61	R086733	Nut - Chuck rotation	1	
62	R099374	Chuck, 7/8" x 31/4" (22 x 82.5 mm)	1	
63	R041321	Sleeve - Chuck, 7/8" x 31/4" (22 x 82.5 mm)	1	
64	R085756	Nut - Thru bolt	2	
65	R041320	Fronthead, 7/8" x 31/4" (22 x 82.5 mm)	1	
66	R093896	Tunnion - Retainer	2	
67	R093897	Buffer - Retainer	1	
68	R093898	Retainer - Latch shoe	1	
69	R093913	Retainer, 7/8" (22 mm)	1	

Comments for Page: CP 0032 A 7/8" x 3 1/4"

(L)OCAL REMARKS

A | 5/8" - 11

B | 1/8"

C | 1/4"

Refer to the Parts Online web page for most up-to-date information. The printed information might be outdated.

Rick G. Walstad
President**INSTRUCTIONS FOR TURNING DRILL SYSTEM ON MODEL 210 SR 4-WAY**

- 1) Loosen set screws on screw jack mast, and adjust the drill frame up until the drill will rest on the ground when lowered in the horizontal position.
- 2) Disconnect the colored 1/4" tubing from the feed cylinder (quick fittings require no tools; simply push red ring in and pull tubing out).
- 3) Disconnect the 3/4" air hose at the "crows foot" connection on the feed bar.
- 4) Remove the 1/2" bolt that is the pivot point when the drill system raises and lowers.
- 5) Disconnect cylinder clevis and lock assembly from "raise and lower" cylinder.
- 6) Disconnect the 3/4" hose from the oiler and from the manifold on the frame.
- 7) Take the disconnected feed system and turn it 180° so that the drill is pointing in the opposite direction from where it was.
- 8) Install the U-shaped fitting assembly onto the oiler.
- 9) Remove plug on air manifold, and install in upper hole on the other side of the manifold.
- 10) Install 3/4" hose by connecting one end to U-shaped fitting, then thread hose around through the main frame under the control panel, and connect the other end to the air manifold where the plug was just removed.
- 11) Install 1/2" bolt in upper hole of feed bar.
- 12) Reconnect the cylinder clevis on "raise and lower" cylinder.
- 13) Reconnect 1/4" tubing to feed cylinder (they are colored coded).
- 14) Adjust screw jack so that the drill will be at the desired height above the ground.
- 15) Tighten set screws on screw jack.

SETTING THE STANDARD FOR CONCRETE DRILLING AND DOWELING