

# TOP PANEL ASSEMBLY

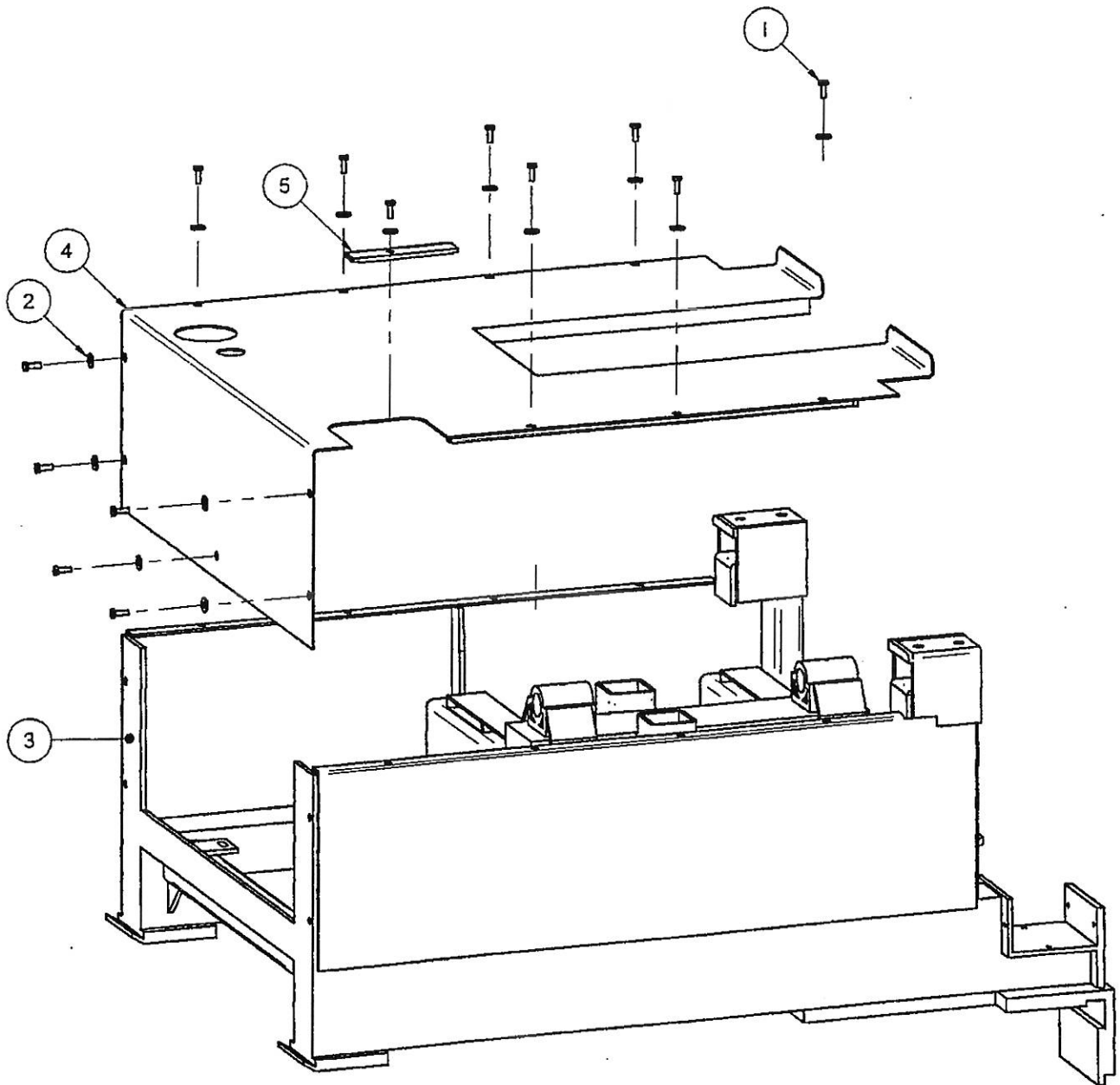

Item Number	File Name	Quantity	Description
1	250IBLT.par	13	1/4" X 3/4" BOLT
2	280IWAS.par	13	1/4" FLAT WASHER
3	HYD3001.par	1	MAIN FRAME
4	HYD3031.par	1	COVER
5	HYD30310.par	1	TOP PANEL TIE DOWN

FNG8022-01

# WEAR SLIDE ASSEMBLY

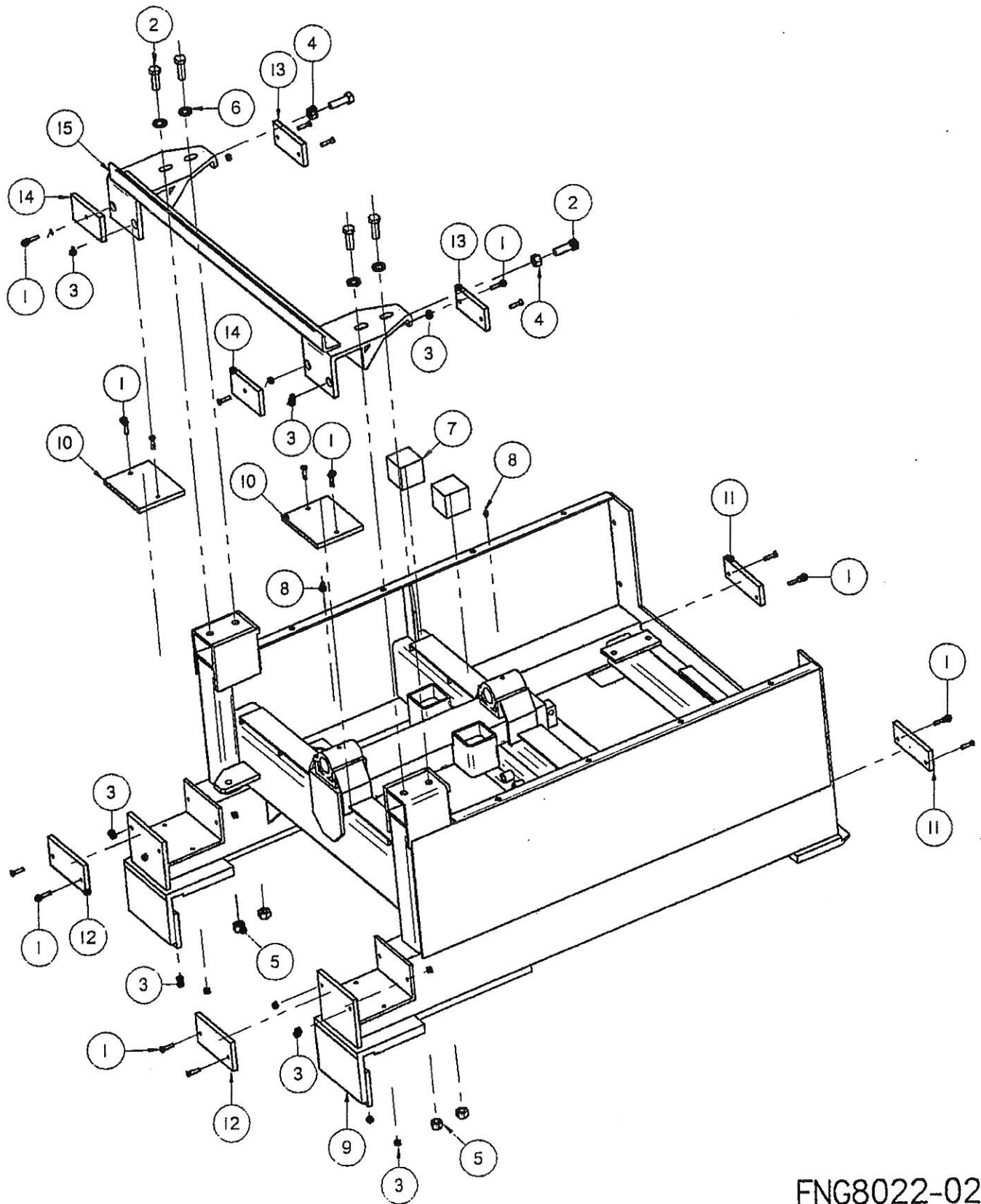

FNG8022-02

# WEAR SLIDE ASSEMBLY

Item Number	File Name	Quantity	Description
1	25030BLT.par	18	1/4" X 1" BRASS FLATHEAD BOLT
2	2562BLT.par	6	1/2" X 1 1/2" BOLT
3	2716NUT.par	18	1/4" NYLON LOCK NUT
4	2732NUT.par	2	1/2" STANDARD NUT
5	2734NUT.par	4	1/2" LOCKNUT
6	2841WAS.par	4	5/16" WASHER
7	4210MIS.par	2	2" X 2" X 2" POLYURETHANE BUSHING
8	9501MIS.par	2	GREASE ZERT
9	HYD3001.par	1	MAIN FRAME
10	HYD3022.par	2	NYLON WEAR PAD
11	HYD302200.par	2	NYLON WEAR PAD
12	HYD302201.par	2	NYLON WEAR PAD
13	HYD302202.par	2	NYLON WEAR PAD
14	HYD302203.par	2	NYLON WEAR PAD
15	HYD3025.par	1	MAST HOLD

FNG8022-03

# MAST ASSEMBLY

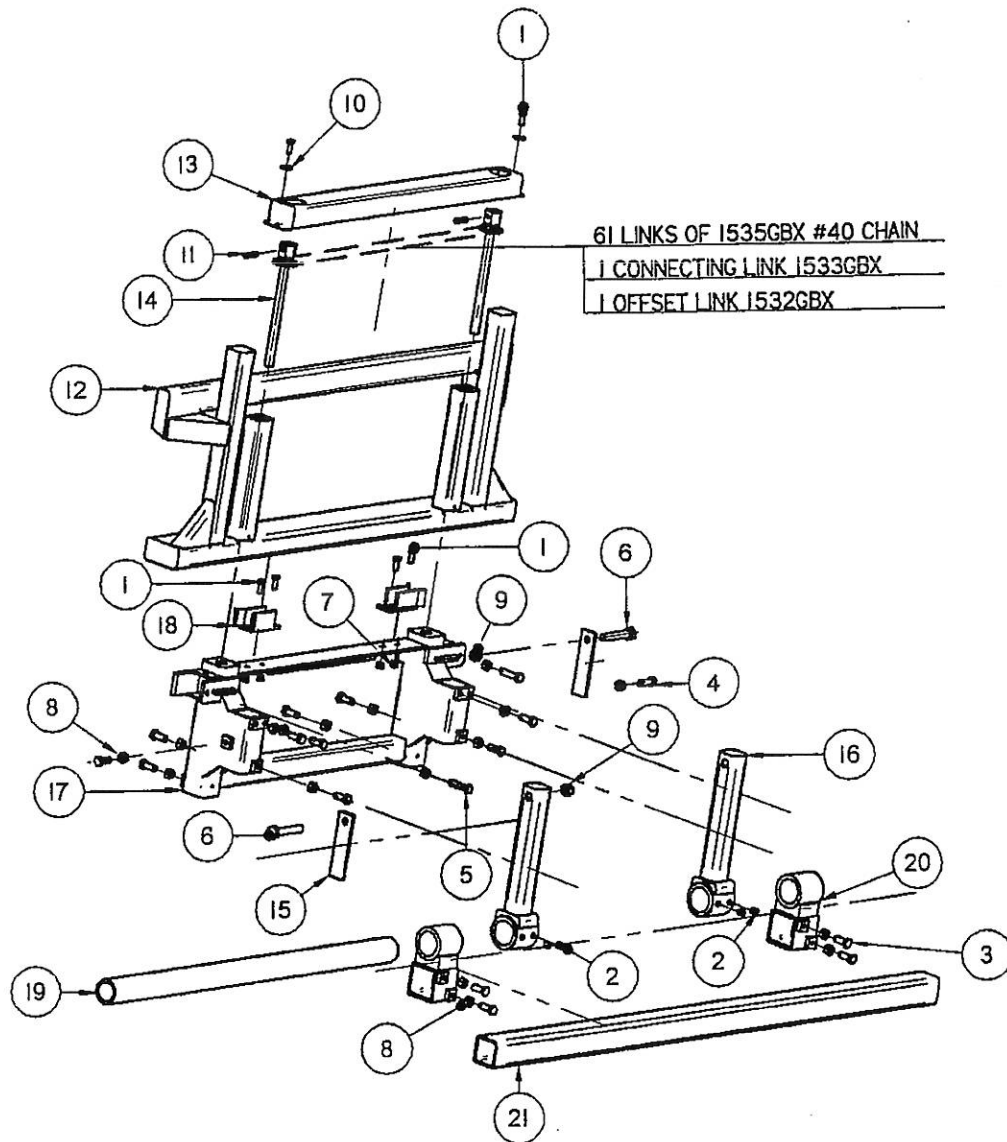

FIGURE 21

TOOL BAR WILL VARY IN LENGTH DEPENDING ON SPACING AND NUMBER OF FEED SYSTEMS

FNG8022-04

# MAST ASSEMBLY

Item Number	File Name	Quantity	Description
1	2538BLT.par	6	3/8" X 1" BOLT
2	25590BLT.par	4	1/2" X 1/2" I3 SET SCREW
3	2560BLT.par	15	1/2" X 1 1/4" BOLT
4	2562BLT.par	1	1/2" X 1 1/2" BOLT
5	25630BLT.par	2	1/2" X 2" TAP BOLT
6	2585BLT.par	2	5/8" X 3 1/2" BOLT
7	2727NUT.par	4	3/8" LOCKNUT
8	2732NUT.par	18	1/2" STANDARD NUT
9	2742NUT.par	2	5/8" LOCKNUT
10	2820WAS.par	2	3/8" FLAT WASHER
11	3006PIN.par	2	3/8" X 1 1/2" ROLL PIN
12	HYD3002.par	1	SLIDE MAST
13	HYD3016.par	1	CHAIN COVER
14	HYD3023.asm	2	SCREW JACK
15	HYD30251.par	2	MAST EXTENSION SUPPORT STRAP
16	HYD3033.par	2	MAST EXTENSION
17	HYD3035.par	1	EQUIPMENT MOUNT MAST
18	SRSI624.par	2	CHAIN TIGHTNER
19	SRSI634.par	1	UPPER TOOL BAR
20	SRSI635.par	2	HINGE
21	SRSI649.par	1	TOOL BAR VARIABLE LENGHTS

FNG8022-05

# SWIVEL CLEVIS ASSEMBLY

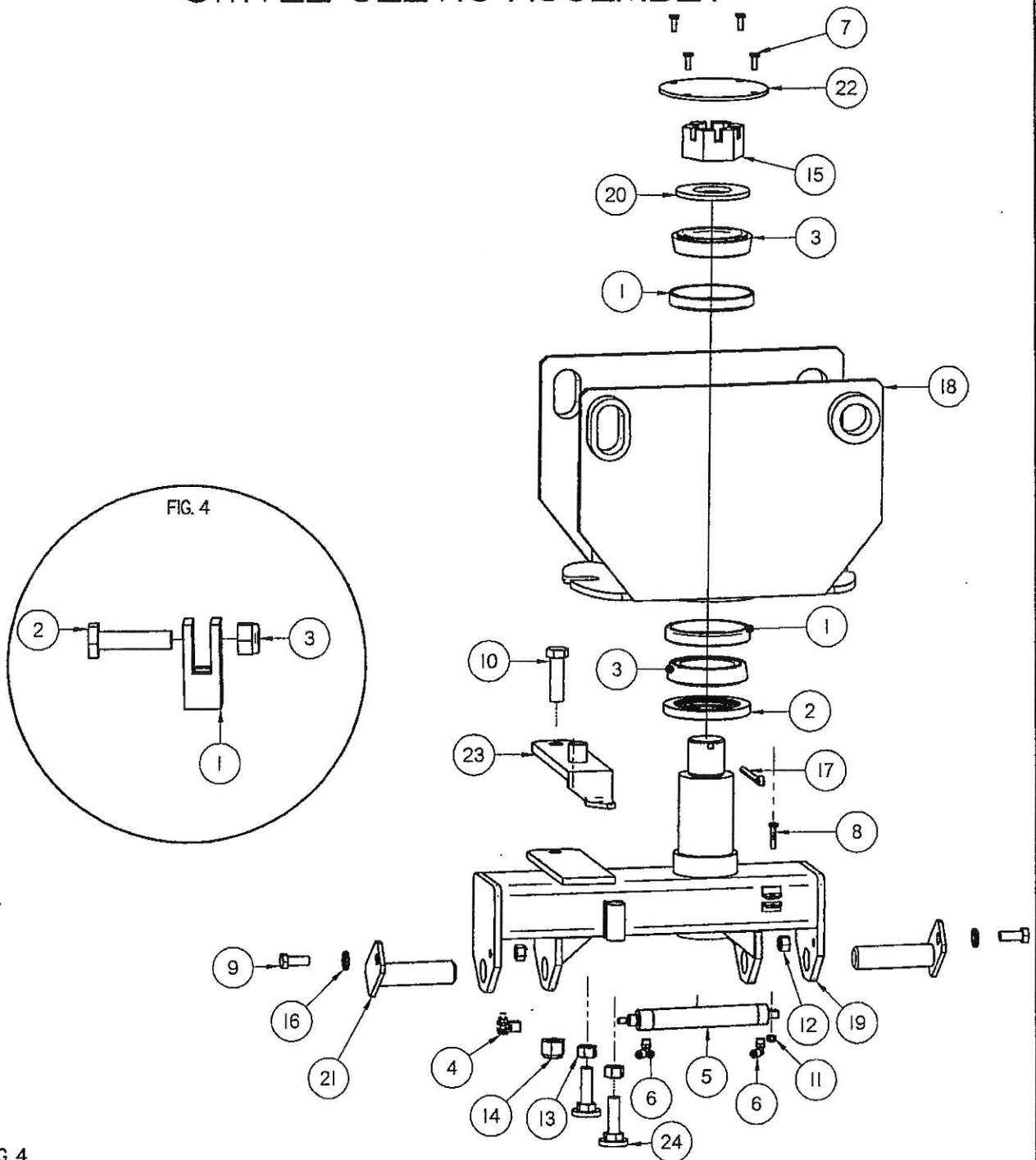

FIG. 4

Item Number	File Name	Quantity	Description
1	05000CYL.par	1	CLEVIS
2	2503BLT.par	1	1/4" X 1" BOLT
3	2716NUT.par	1	1/4" NYLON LOCK NUT

FNG8022-06

# SWIVEL CLEVIS ASSEMBLY

Item Number	File Name	Quantity	Description
1	04090BRG.par	2	TIMKEN RACE BEARING
2	04091BRG.par	1	BEARING SEAL
3	0409BRG.par	2	TIMKEN BEARING
4	05000CYL.asm	1	BRAKE CYLINDER CLEVIS
5	05046CYL.par	1	SWIVEL LOCK CYLINDER
6	2050FIT.par	2	1/4" TO 1/8" 90 DEG. FITTING
7	2501BLT.par	4	1/4" X 3/4" BOLT
8	2505BLT.par	1	1/4" X 1 1/4" BOLT
9	2560BLT.par	2	1/2" X 1 1/4" BOLT
10	2599BLT.par	1	3/4" X 2 1/2" BOLT
11	2716NUT.par	1	1/4" NYLON LOCK NUT
12	2734NUT.par	2	1/2" LOCKNUT
13	2740NUT.par	2	5/8" STANDARD NUT
14	2749NUT.par	1	3/4" NYLON LOCK NUT
15	2760NUT.par	1	CASTLE NUT
16	2832WAS.par	2	1/2" WASHER
17	30227PIN.par	1	5/16" X 4" COTTER PIN
18	HYD3004.par	1	SWIVEL
19	HYD3005.par	1	SWIVEL CLEVIS
20	HYD30050.par	1	SWIVEL CLEVIS WASHER
21	HYD3006.par	2	SWIVEL PIN
22	HYD3008.par	1	SWIVEL CLEVIS CAP
23	HYD3009.par	1	SWIVEL LOCK
24	HYD30291.par	2	LEVELING FOOT

FNG8022-07

# REGULATOR BOX ASSEMBLY

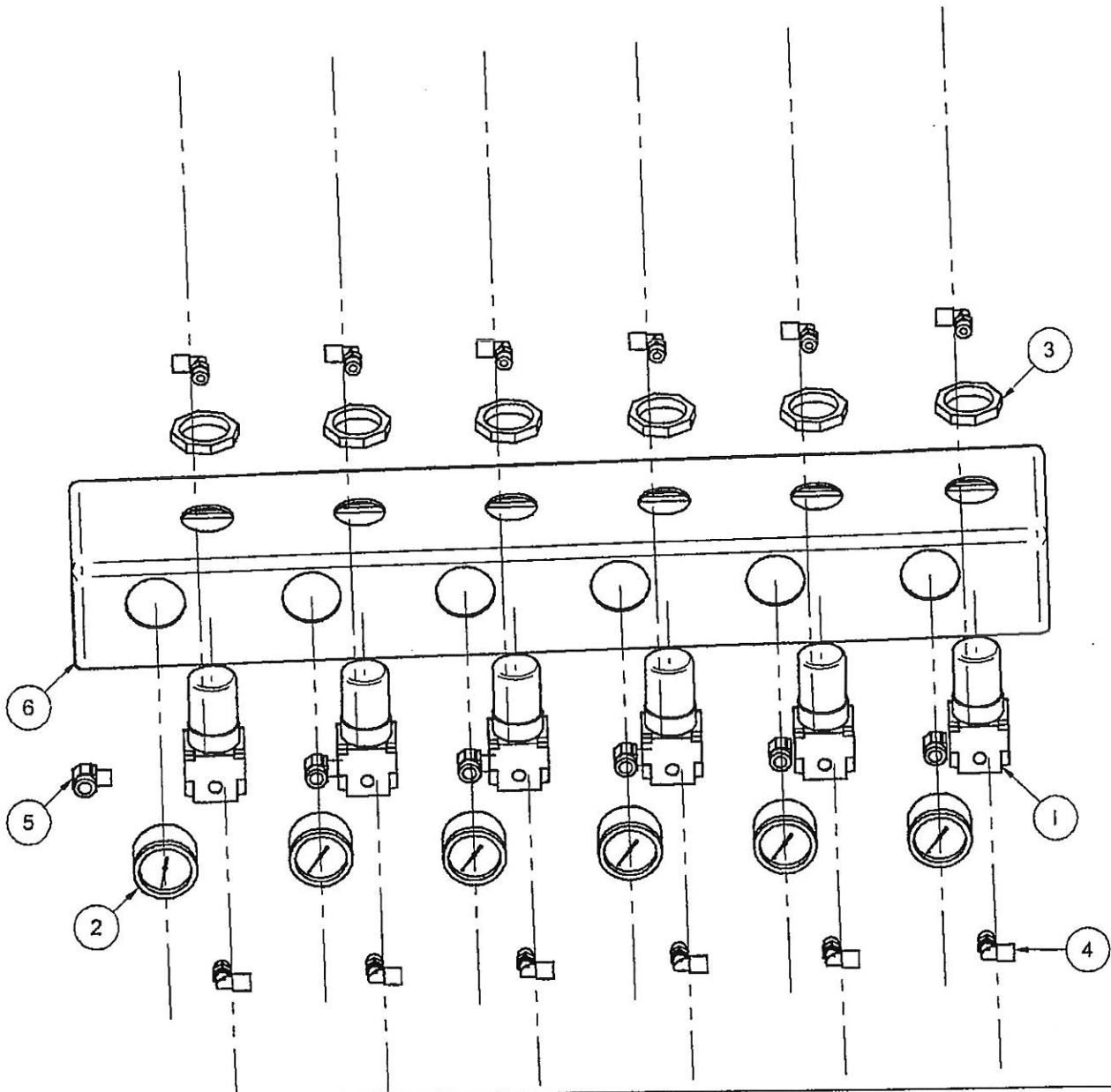

Item Number	File Name	Quantity	Description
1	08101REG.par	6	REGULATOR WITH LOCK RING
2	09022GAU.par	6	GAUGE 0-60 1/8" MPT
3	17056RPT.par	6	LOCK RING FOR 08101REG
4	2050FIT.par	12	1/4" TO 1/8" 90 DEG. FITTING
5	2153PFT.par	6	1/8" BRASS 90
6	HYD30100.par	1	REGULATOR BOX

FNG8022-08



# CONTROL PANEL ASSEMBLY

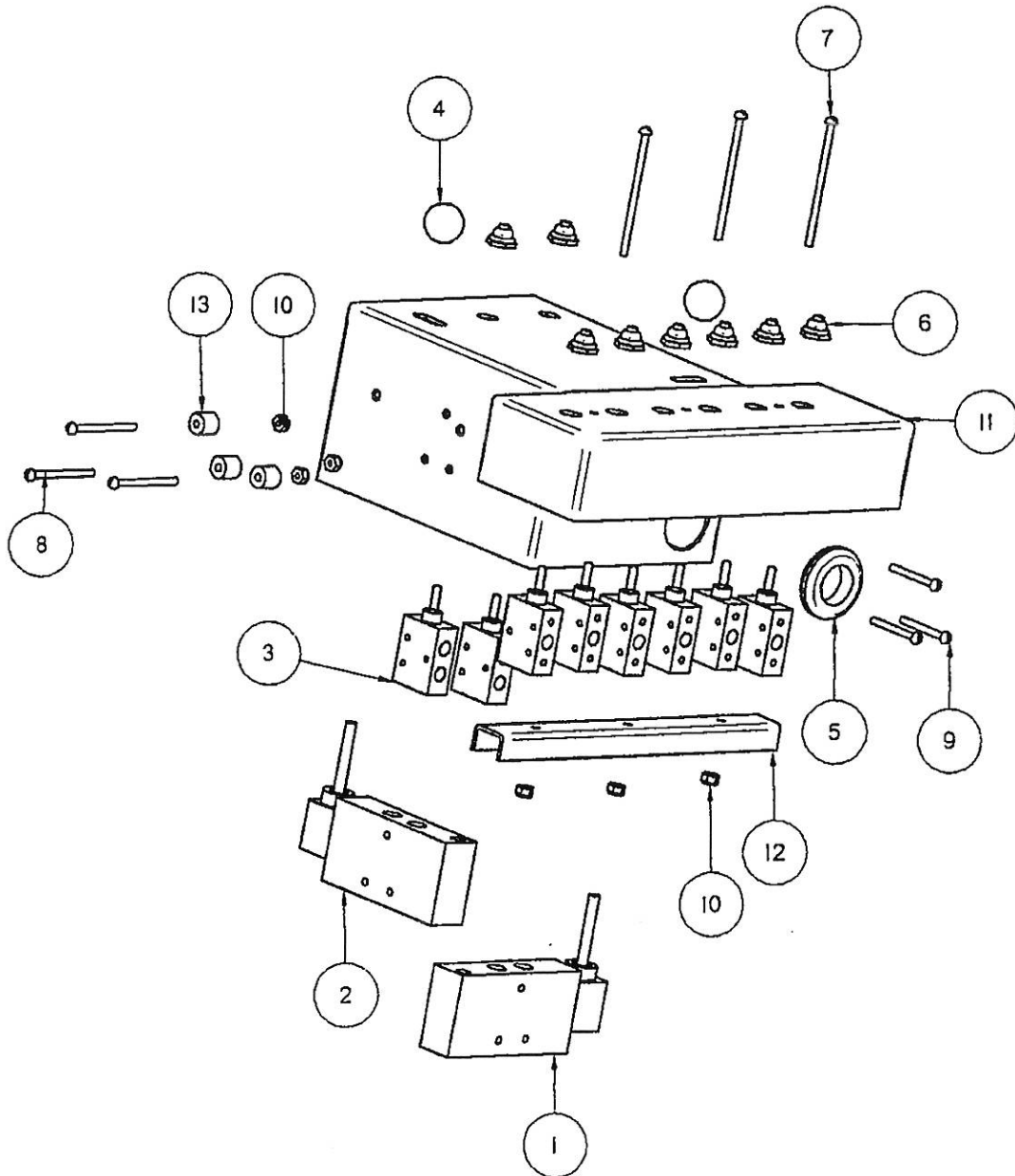

FNG8022-09

# CONTROL PANEL ASSEMBLY

Item Number	File Name	Quantity	Description
1	060100VAL.par	1	SIDE SHIFT VALVE
2	060101VAL.par	1	FEED VALVE WITH KNOB
3	06095VAL.par	8	TOGGLE SWITCH
4	17420IRPT.par	2	KNOB
5	18030GRO.par	1	GROMMET
6	1828GRO.par	8	RED BOOT FOR 06095VAL
7	247800blt.Par	3	8/32" X 3" BOLT
8	24780BLT.par	3	8/32" X 2" BOLT
9	2478BLT.par	3	8/32" X 1 1/2" BOLT
10	2712NUT.par	6	8/32" NYLON LOCK NUT
11	HYD3010.par	1	CONTROL PANEL
12	HYD30320.par	1	VALVE SUPPORT BRACKET
13	HYD30321.par	3	VALVE SPACER

FNG8022-10

# CONTROL PANEL ASSEMBLY

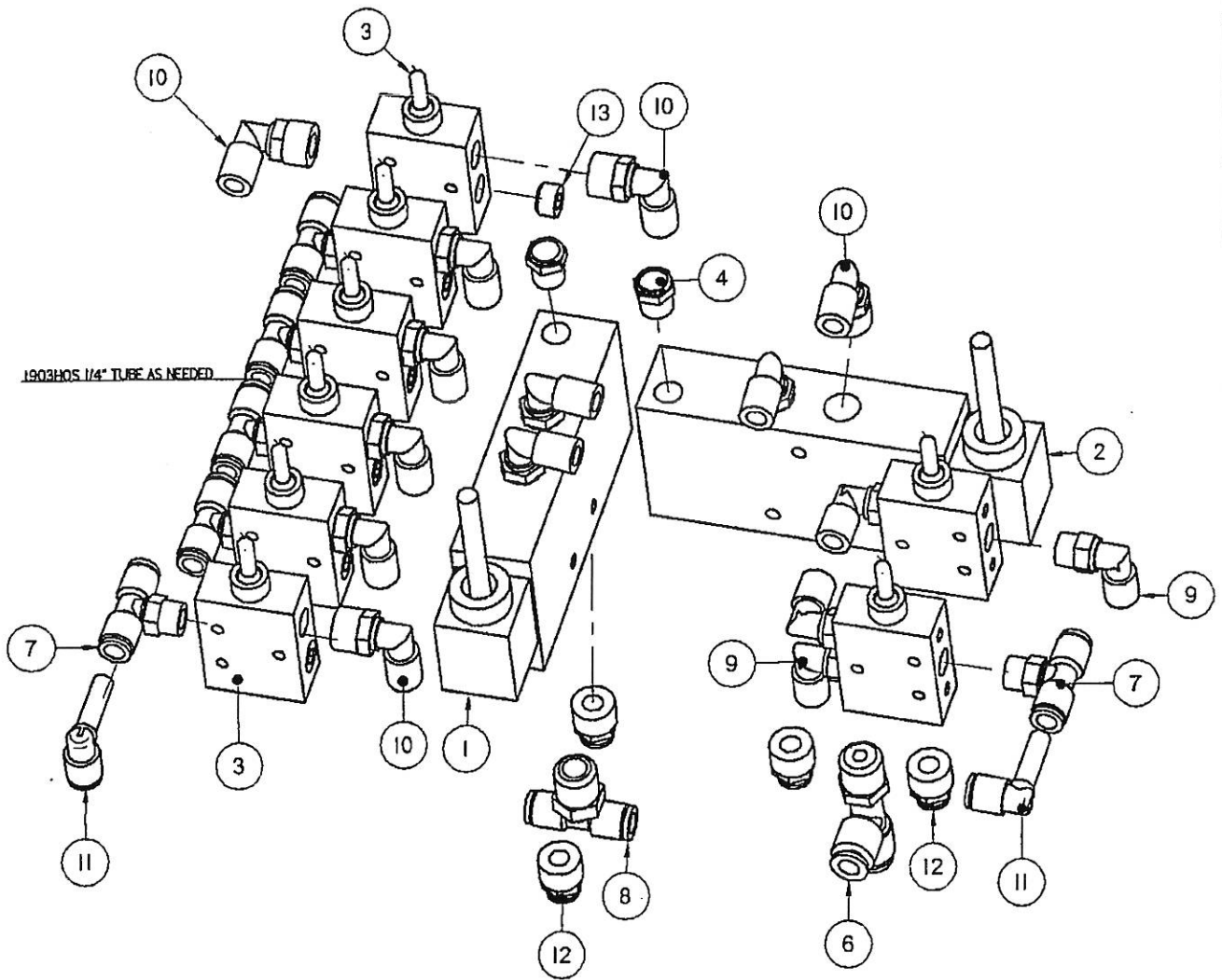

FNG8022-11

# CONTROL PANEL ASSEMBLY

Item Number	File Name	Quantity	Description
1	060100VAL.par	1	SIDE SHIFT VALVE
2	060101VAL.par	1	FEED VALVE WITH KNOB
3	06095VAL.par	8	TOGGLE SWITCH
4	100IBRV.par	2	1/8" BREATHER VENT
5	17420IRPT.par	2	KNOB
6	2035FIT.par	1	1/4" X 1/4" MALE RUN T
7	2041OFIT.par	6	1/8"MPT 1/4" BRANCH T
8	2041FIT.par	1	1/4" BRANCH T
9	2050FIT.par	4	1/4" TO 1/8" 90 DEG. FITTING
10	2051FIT.par	11	1/4" TO 1/4" 90 DEG. FITTING
11	20580FIT.par	2	1/4" PLUG IN ELBOW
12	2067FIT.par	4	1/4" TO 1/4" MALE CONNECTOR
13	21010PFT.par	7	1/8" PIPE PLUG

FNG8022-12

# HORIZONTAL ADJUSTMENT ASSEMBLY FOR 2, 4, AND 6 GANG DRILLS

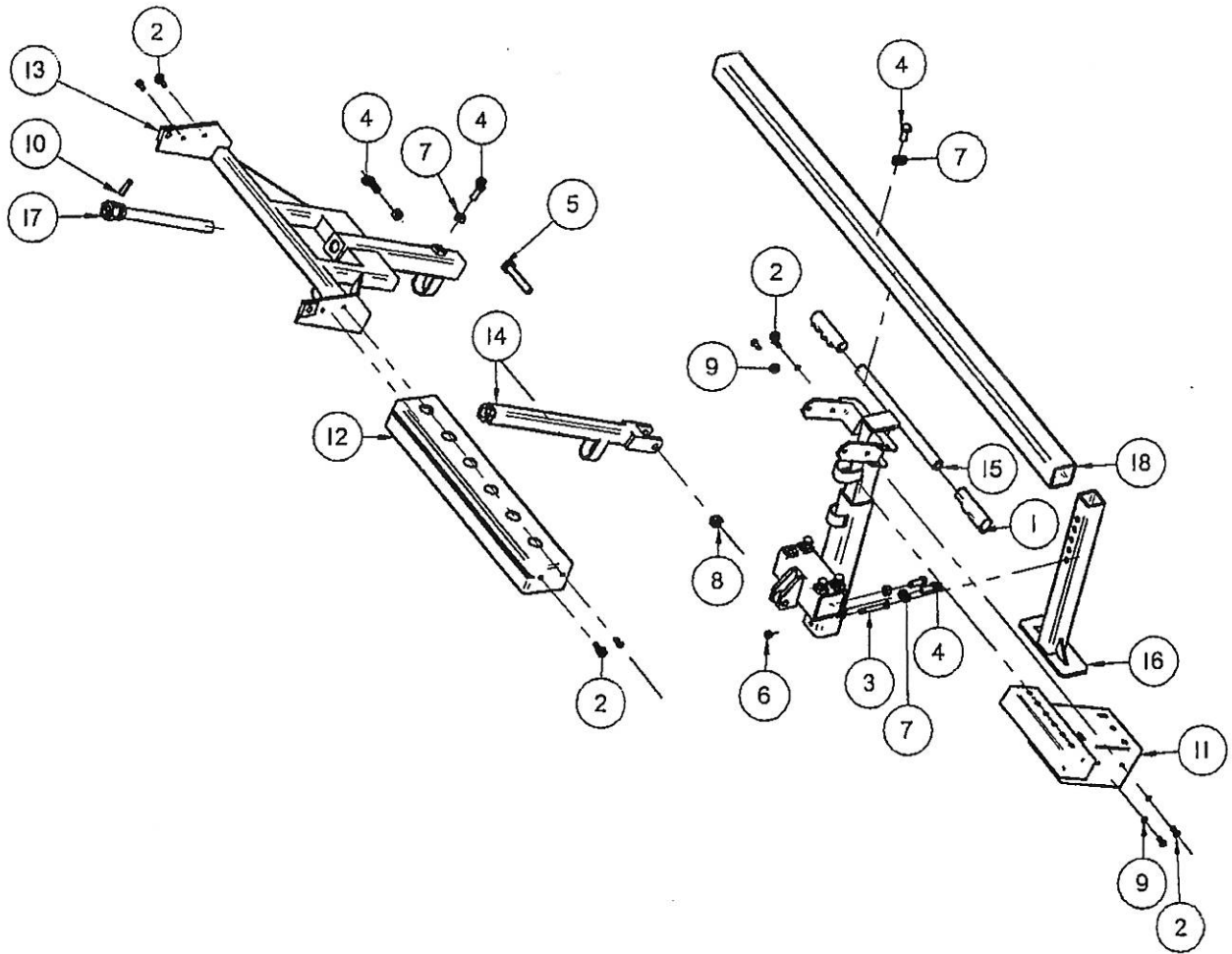

FNG8022-13

# HORIZONTAL ADJUSTMENT ASSEMBLY FOR 2, 4, AND 6 GANG DRILLS

Item Number	File Name	Quantity	Description
1	1820GR0.par	2	HANDLE GRIP
2	2519BLT.par	8	5/16" X 3/4" BOLT
3	2547BLT.par	1	3/8" X 3" BOLT
4	2560BLT.par	8	1/2" X 1 1/4" BOLT
5	2585BLT.par	1	5/8" X 3 1/2" BOLT
6	2727NUT.par	1	3/8" LOCKNUT
7	2732NUT.par	8	1/2" STANDARD NUT
8	2743NUT.par	1	5/8" NYLON LOCK NUT
9	2810WAS.par	4	5/16" LOCK WASHER
10	3006PIN.par	1	3/8" X 1 1/2" ROLL PIN
11	HYD3010.par	1	CONTROL PANEL
12	HYD30100.par	1	REGULATOR BOX
13	HYD30110.par	1	UPPER HORIZONTAL ADJUSTING ARM
14	HYD30121.par	1	LOWER ADJUSTING HORIZONTAL ARM 2,4,6
15	HYD3019.par	1	SHIFT CONTROL HANDLE HYDRAULIC
16	HYD3020.par	1	STORAGE FOOT FOR 4,6 GANG
17	HYD30230.asm	1	SCREW JACK ASSEMBLY
18	SRS1649.par	1	TOOL BAR VARIABLE LENGHTS

FNG8022-14

# HORIZONTAL ADJUSTMENT ASSEMBLY FOR 3 & 5 GANG DRILLS

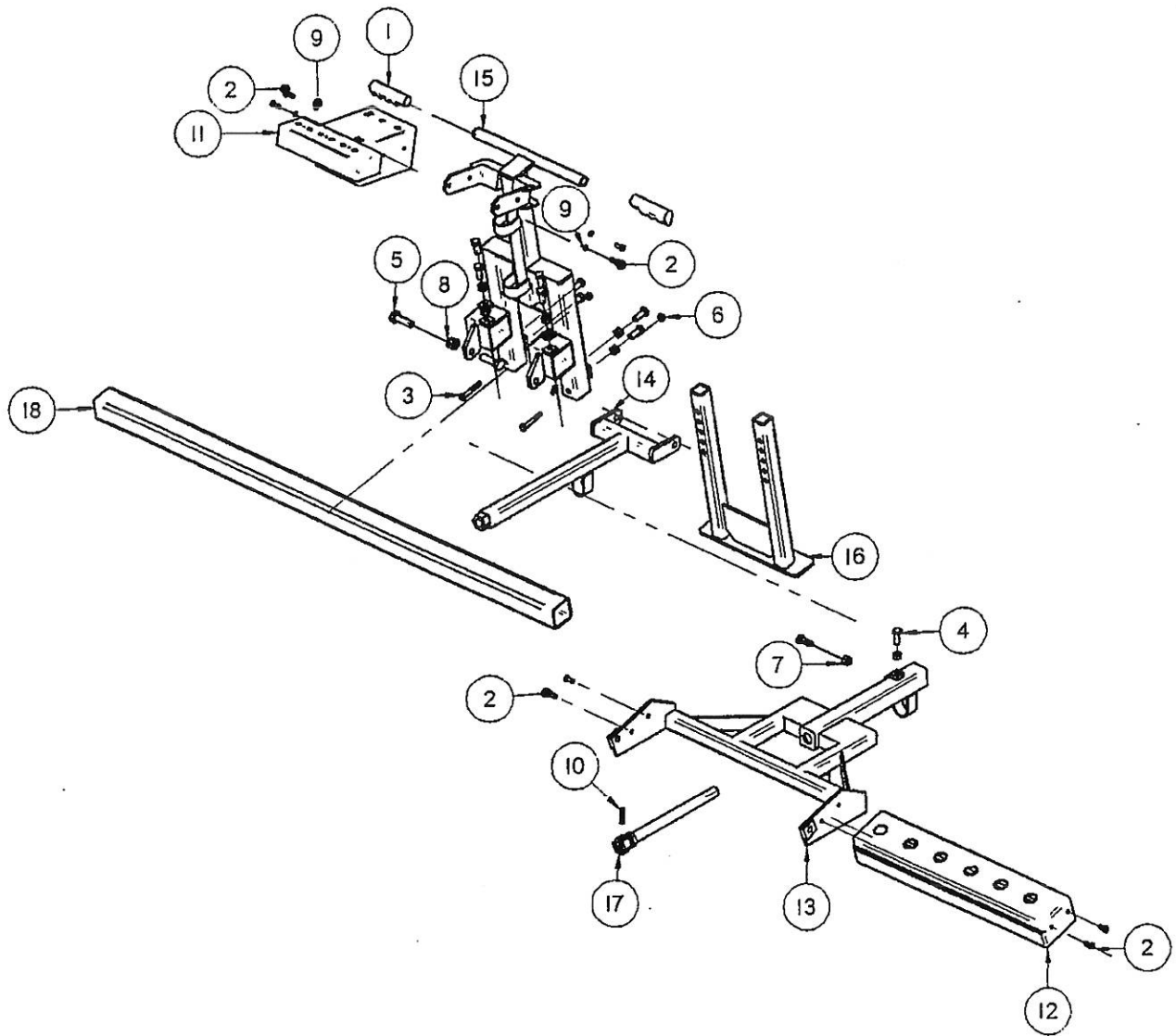

FNG8022-15

# HORIZONTAL ADJUSTMENT ASSEMBLY FOR 3 & 5 GANG DRILLS

Item Number	File Name	Quantity	Description
1	1820GR0.par	2	HANDLE GRIP
2	2519BLT.par	8	5/16" X 3/4" BOLT
3	2546BLT.par	2	3/8" X 2 1/2" BOLT
4	2560BLT.par	10	1/2" X 1 1/4" BOLT
5	2582BLT.par	2	5/8" X 2" BOLT
6	2727NUT.par	2	3/8" LOCKNUT
7	2732NUT.par	10	1/2" STANDARD NUT
8	2743NUT.par	2	5/8" NYLON LOCK NUT
9	2810WAS.par	4	5/16" LOCK WASHER
10	3006PIN.par	1	3/8" X 1 1/2" ROLL PIN
11	HYD3010.par	1	CONTROL PANEL
12	HYD30100.par	1	REGULATOR BOX
13	HYD30110.par	1	UPPER HORIZONTAL ADJUSTING ARM
14	HYD30120.par	1	LOWER HORIZONTAL ADJUSTING ARM 3,5 GANG
15	HYD3018.par	1	SHIFT CONTROL HANDLE HYDRAULIC
16	HYD3021.par	1	STORAGE FOOT
17	HYD30230.asm	1	SCREW JACK ASSEMBLY
18	SRS1649.par	1	TOOL BAR VARIABLE LENGHTS

FNG8022-16



# FEED BAR ASSEMBLY

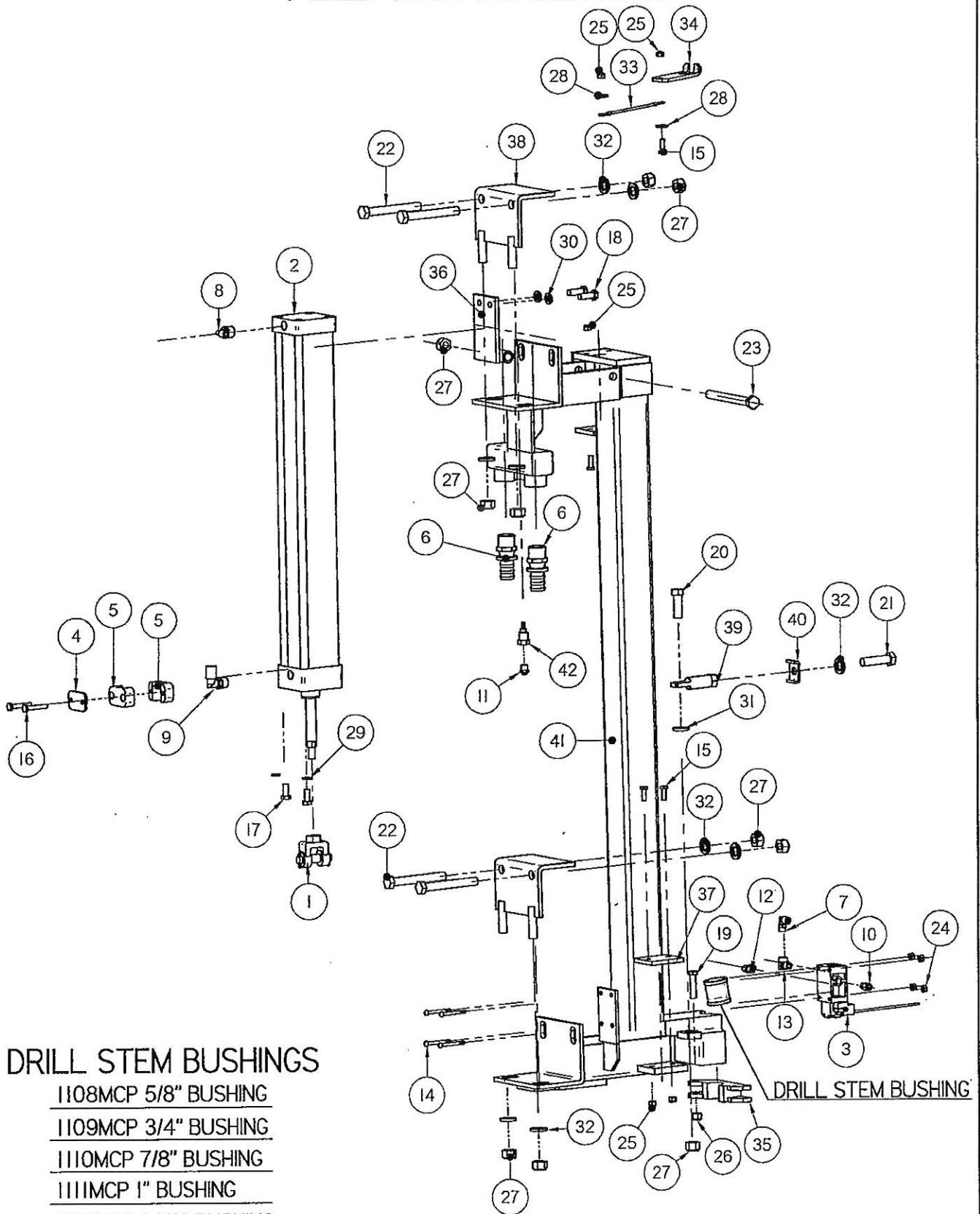

## DRILL STEM BUSHINGS

- 1108MCP 5/8" BUSHING
- 1109MCP 3/4" BUSHING
- 1110MCP 7/8" BUSHING
- 1111MCP 1" BUSHING
- 1112MCP 1 1/8" BUSHING

DRILL STEM BUSHING

FNG8022-17

# FEED BAR ASSEMBLY

Item Number	File Name	Quantity	Description
1	0501CYL.asm	1	CLEVIS FOR 5/8" ROD
2	05140CYL.asm	1	2.5" X 20" FEED CYLINDER
3	0608VAL.par	1	AUTOMATIC SHUT OFF VALVE
4	192309HOS.par	1	1" VIBRATION DAMPING HOSE CLAMP
5	192309HOS.par	2	1" VIBRATION DAMPING HOSE CLAMP
6	1999FIT.par	2	3/4" X 3/4" HOSE SWIVEL
7	2050FIT.par	1	1/4" TO 1/8" 90 DEG. FITTING
8	2052FIT.par	1	1/4" TO 3/8" 90 DEG. FITTING
9	2054FIT.par	1	3/8" X 3/8" 90 DEG. FITTING
10	2066FIT.par	1	1/4" TO 1/8" MALE CONNECTOR
11	20750FIT.par	1	1/8" X 1/8" MALE FITTING
12	20751FIT.par	1	1/8" X 1/8" 90 DEG. SWIVEL
13	2153PFT.par	1	1/8" BRASS 90
14	2484BLT.par	4	3/16" X 1 3/4" BOLT
15	2501BLT.par	5	1/4" X 3/4" BOLT
16	2506BLT.par	2	1/4" X 1 1/2" BOLT
17	2516BLT.par	2	5/16" X 3/4" FINE THREAD BOLT
18	2538BLT.par	2	3/8" X 1" BOLT
19	2541BLT.par	1	3/8" X 1 1/2" BOLT
20	2562BLT.par	1	1/2" X 1 1/2" BOLT
21	2563BLT.par	1	1/2" X 2" BOLT
22	2570BLT.par	4	1/2" X 4" BOLT
23	2575BLT.par	1	1/2" X 5" BOLT
24	2713NUT.par	4	3/16" NYLON LOCK NUT
25	2716NUT.par	5	1/4" NYLON LOCK NUT
26	2727NUT.par	1	3/8" LOCKNUT
27	2734NUT.par	10	1/2" LOCKNUT
28	2801WAS.par	2	1/4" FLAT WASHER
29	2810WAS.par	2	5/16" LOCK WASHER
30	2821WAS.par	2	3/8" LOCK WASHER
31	2831WAS.par	1	7/8"OD X 1/2"ID WASHER 10GA.
32	2832WAS.par	9	1/2" WASHER
33	3030PIN.par	1	6" LANYARD WITH LOOPS
34	CRA0218.par	1	CARRIAGE LOCK
35	MFA0609.par	1	BIT GUIDE
36	MFA0625.par	1	FEED CYLINDER MOUNT BRACKET
37	MFA0626.par	2	STOP PAD
38	MFA0642.par	2	FRAME CLAMP
39	MFA0674.par	1	SWIVEL BOLT
40	MFA0690.par	1	BIT GUIDE KEEPER
41	SRS1633.par	1	FEED BAR
42	SRS1666.par	1	OIL INJECTOR

FNG8022-18

# MIDDLE FEED BAR ASSEMBLY FOR 3 & 5 GANG

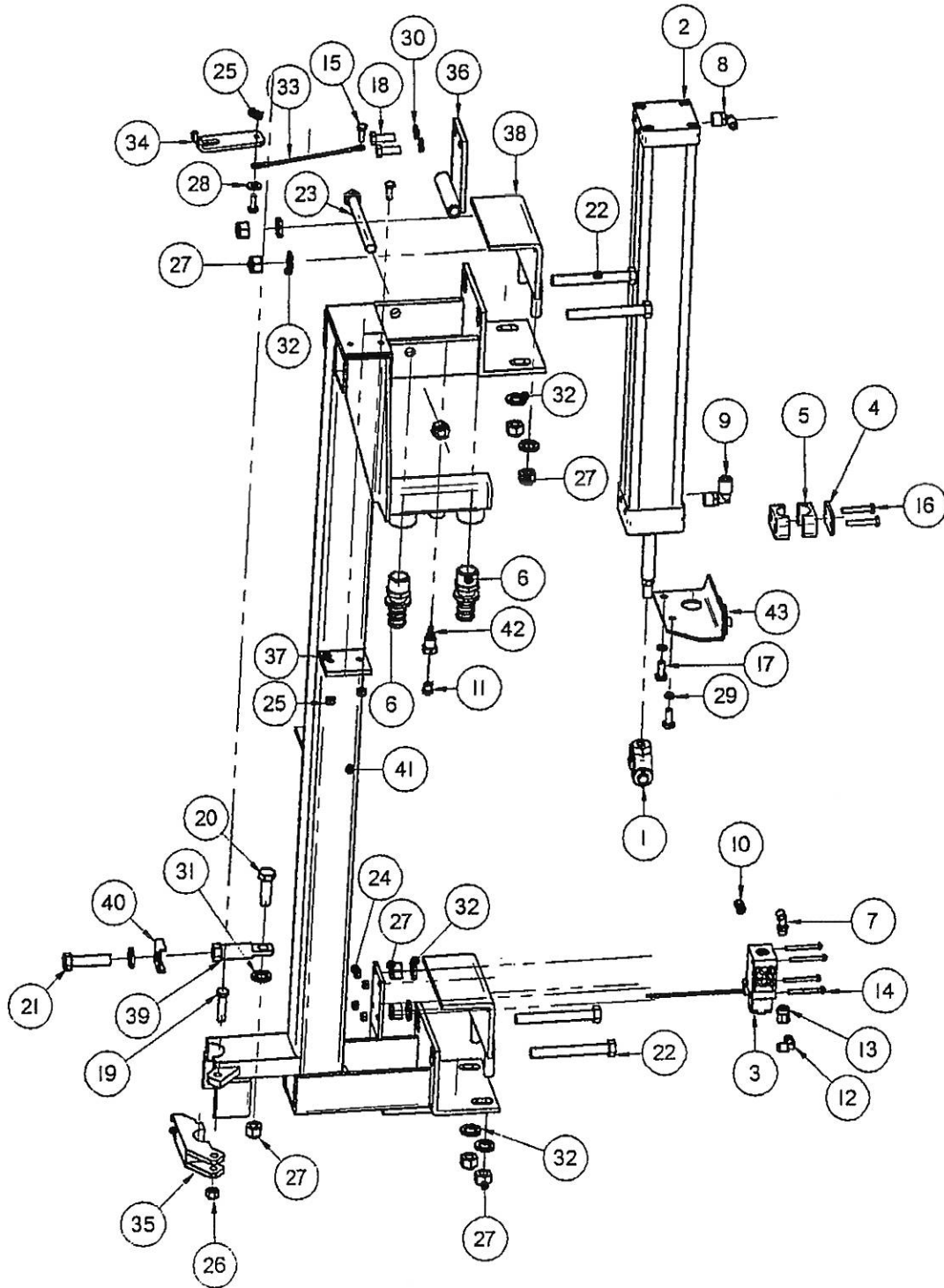

FNG8022-19

# MIDDLE FEED BAR ASSEMBLY FOR 3 & 5 & GANG

Item Number	File Name	Quantity	Description
1	0501CYL.asm	1	CLEVIS FOR 5/8" ROD
2	05140CYL.asm	1	2.5" X 20" FEED CYLINDER
3	0608VAL.par	1	AUTOMATIC SHUT OFF VALVE
4	192309HOS.par	1	1" VIBRATION DAMPING HOSE CLAMP
5	192309HOS.par	2	1" VIBRATION DAMPING HOSE CLAMP
6	1999FIT.par	2	3/4" X 3/4" HOSE SWIVEL
7	2050FIT.par	1	1/4" TO 1/8" 90 DEG. FITTING
8	2052FIT.par	1	1/4" TO 3/8" 90 DEG. FITTING
9	2054FIT.par	1	3/8" X 3/8" 90 DEG. FITTING
10	2066FIT.par	1	1/4" TO 1/8" MALE CONNECTOR
11	20750FIT.par	1	1/8" X 1/8" MALE FITTING
12	20751FIT.par	1	1/8" X 1/8" 90 DEG. SWIVEL
13	2153PFT.par	1	1/8" BRASS 90
14	2484BLT.par	4	3/16" X 1 3/4" BOLT
15	2501BLT.par	5	1/4" X 3/4" BOLT
16	2506BLT.par	2	1/4" X 1 1/2" BOLT
17	2516BLT.par	2	5/16" X 3/4" FINE THREAD BOLT
18	2538BLT.par	2	3/8" X 1" BOLT
19	2541BLT.par	1	3/8" X 1 1/2" BOLT
20	2562BLT.par	1	1/2" X 1 1/2" BOLT
21	2563BLT.par	1	1/2" X 2" BOLT
22	2570BLT.par	4	1/2" X 4" BOLT
23	2575BLT.par	1	1/2" X 5" BOLT
24	2713NUT.par	4	3/16" NYLON LOCK NUT
25	2716NUT.par	5	1/4" NYLON LOCK NUT
26	2727NUT.par	1	3/8" LOCKNUT
27	2734NUT.par	10	1/2" LOCKNUT
28	2801WAS.par	1	1/4" FLAT WASHER
29	2810WAS.par	2	5/16" LOCK WASHER
30	2821WAS.par	2	3/8" LOCK WASHER
31	2831WAS.par	1	7/8"OD X 1/2"ID WASHER 10GA
32	2832WAS.par	9	1/2" WASHER
33	3030PIN.par	1	6" LANYARD WITH LOOPS
34	CRA0218.par	1	CARRIAGE LOCK
35	MFA0609.par	1	BIT GUIDE
36	MFA0625.par	1	FEED CYLINDER MOUNT BRACKET
37	MFA0626.par	2	STOP PAD
38	MFA0642.par	2	FRAME CLAMP
39	MFA0674.par	1	SWIVEL BOLT
40	MFA0690.par	1	BIT GUIDE KEEPER
41	SRS16325.par	1	FEED BAR
42	SRS1666.par	1	OIL INJECTOR
43	SRS16801.par	1	HOSE MOUNT BRACKET

FNG8022-20

# CARRIAGE ASSEMBLY

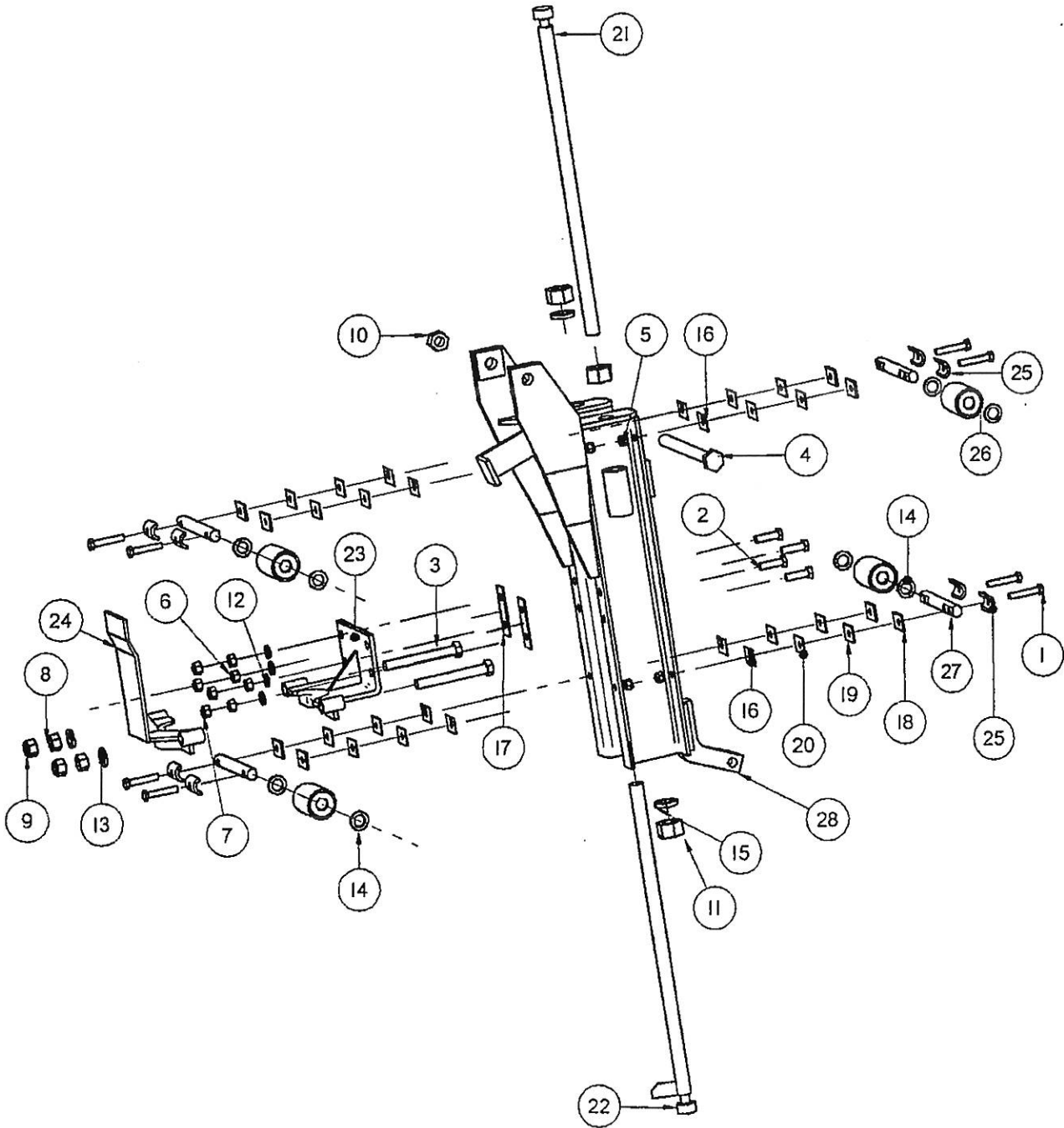

FNG8022-21

# CARRIAGE ASSEMBLY

Item Number	File Name	Quantity	Description
1	2526BLT	8	5/16" X 1-1/2" BOLT
2	2540BLT.par	4	3/8" X 1 1/4" BOLT
3	2570BLT.par	2	1/2" X 4" BOLT
4	2590BLT.par	1	5/8" X 8" BOLT
5	2719NUT.par	4	5/16" NYLON LOCK NUT
6	2725NUT.par	4	3/8" STANDARD NUT
7	2727NUT.par	4	3/8" LOCKNUT
8	2732NUT.par	2	1/2" STANDARD NUT
9	2734NUT.par	2	1/2" LOCKNUT
10	2742NUT.par	1	5/8" LOCKNUT
11	27490NUT.par	4	3/4" COIL ROD NUT
12	2821WAS.par	4	3/8" LOCK WASHER
13	2832WAS.par	2	1/2" WASHER
14	2841WAS.par	8	5/16" WASHER
15	2852WAS.par	2	3/4" LOCK WASHER
16	7009TAB.par	8	STAINLESS STEEL SHIM (AS NEEDED)
17	7010TAB.par	2	16 GA. TWO HOLE SHIM
18	7011TAB.par	8	12 GA. SHIM (AS NEEDED)
19	7012TAB.par	8	18 GA. SHIM (AS NEEDED)
20*	7013TAB.par	8	22 GA. SHIM (AS NEEDED)
21	Cra02030Par	1	18" STOP ROD
22	CRA02040.par	1	18" STOP ROD WITH TAB
23*	CRA0214.par	1	UPPER DRILL BRACKET
24	CRA0216.par	1	LOWER DRILL BRACKET
25	CRA0230.par	8	BEARING KEEPER
26	CRA0233.par	4	ROLLER BEARING DRUM
27	CRA0234.par	4	ROLLER BEARING AXLE
28	CRG01041.par	1	CARRIAGE

FNG8022-22

# INTERNAL VALVE ASSEMBLY

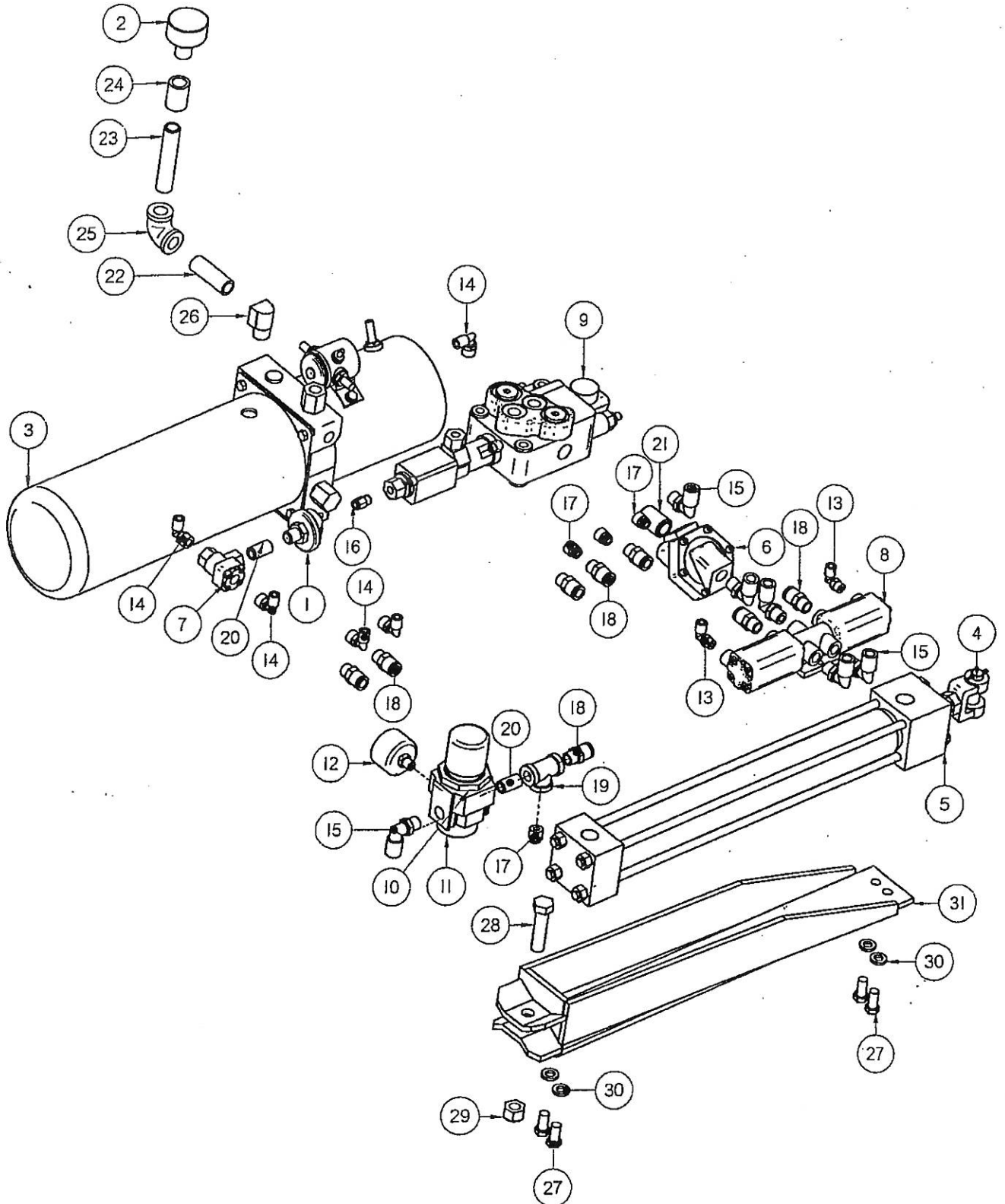

FNG8022-23

# INTERNAL VALVE ASSEMBLY

Item Number	File Name	Quantity	Description
1	0101ELE.par	1	12V AIR SWITCH
2	0137ELE.par	1	PLUG FOR HYDRAULIC PUMP
3	0137ELE.par	1	HYDRAULIC PUMP
4	0501CYL.asm	1	CLEVIS WITH PIN FOR 5/8" ROD
5	05501CYL.asm	1	1.5" X 14" SIDE SHIFT CYLINDER
6	0604VAL.par	1	QUICK EXHAUST VALVE
7	06140VAL.par	1	SHUTTLE VALVE
8	06166VAL.par	1	4 WAY PILOT OPERATED VALVE
9	0630IVAL.par	1	CLOSED CENTER PILOT OPERATOR VALVE
10	08059REG.par	1	REGULATOR LOCK RING
11	0810REG.par	1	REGULATOR WITH LOCK RING
12	09023GAU.par	1	0-160 GAUGE
13	2050FIT.par	2	1/4" TO 1/8" 90 DEG. FITTING
14	2051FIT.par	6	1/4" TO 1/4" 90 DEG. FITTING
15	2053FIT.par	6	3/8" TO 1/4" MALE 90
16	2066FIT.par	1	1/4" TO 1/8" MALE CONNECTOR
17	2067FIT.par	4	1/4" TO 1/4" MALE CONNECTOR
18	2070FIT.par	9	3/8" TO 1/4" MALE CONNECTOR
19	21023PFT.par	1	1/4" PIPE TEE
20	2109PFT.par	2	1/4" CLOSE NIPPLE
21	2111PFT.par	1	1/2" X 1" NIPPLE
22	21242PFT.par	1	3/8" X 2" NIPPLE
23	21246PFT.par	1	3/8" X 4" NIPPLE
24	2145PFT.par	1	3/8" COUPLING
25	21563PFT.par	1	3/8" 90 DEG. ELBOW
26	2158PFT.par	1	3/8" STRAIGHT BRASS STREET ELBOW
27	2537BLT.par	4	3/8" X 3/4" BOLT
28	2563BLT.par	1	1/2" X 2" BOLT
29	2734NUT.par	1	1/2" LOCKNUT
30	2821WAS.par	4	3/8" LOCK WASHER
31	HYD3007.par	1	CYLINDER MOUNT HYD

FNG8022-24



# OIL TANK ASSEMBLY

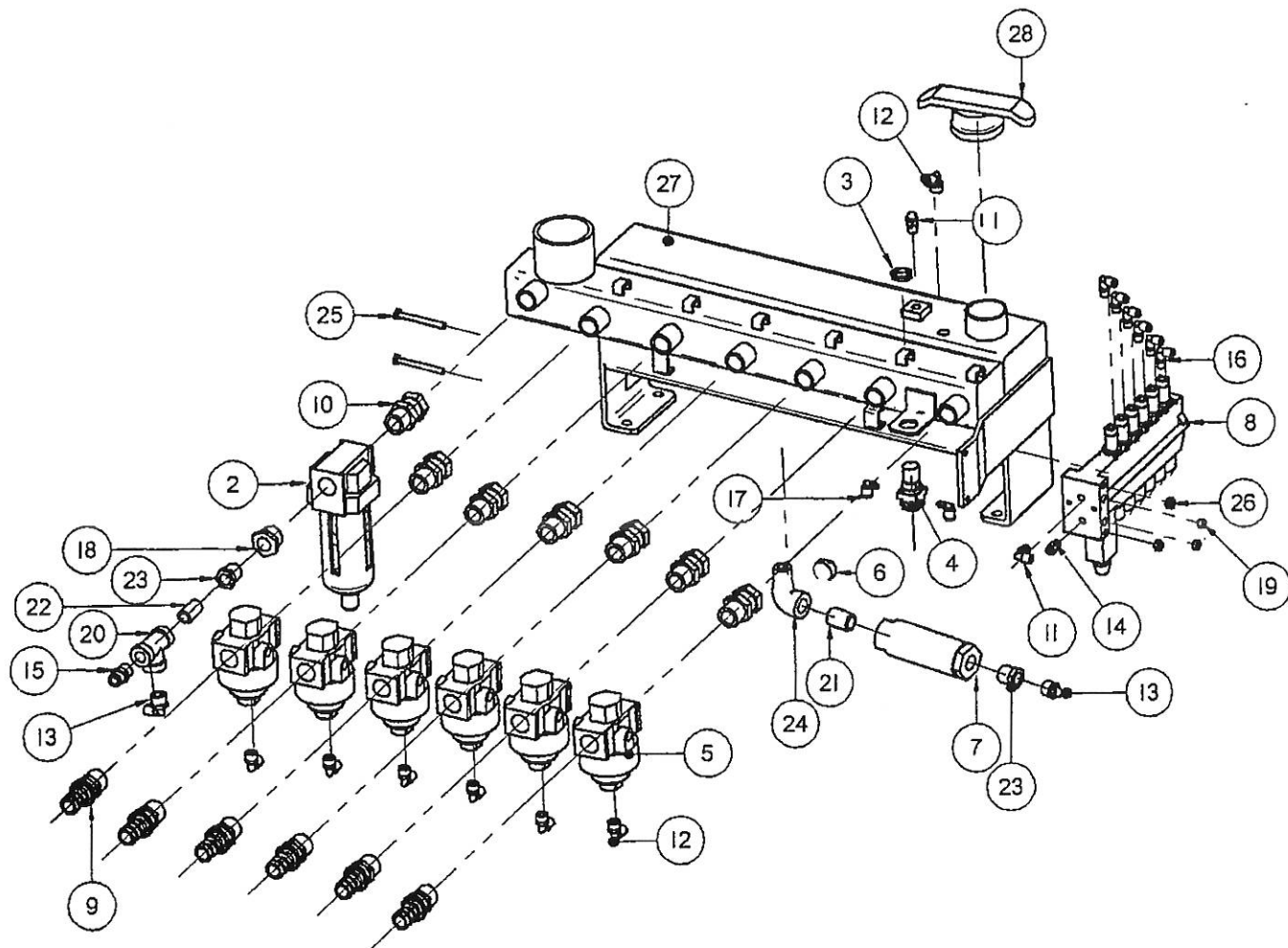

FNG8022-25

# OIL TANK ASSEMBLY

Item Number	File Name	Quantity	Description
1	06055VAL.par	1	BUTTON BLEEDER VALVE
2	08018REG.par	1	3/4" FILTER WITH AUTO DRAIN
3	08108REG.par	1	LOCK RING FOR 08108REG
4	08108REG.par	1	REGULATOR WITH 0-125 MAX PSI
5	08113REG.par	6	3/4" REGULATOR
6	09024GAU.par	1	GAUGE 0-150 MAX PSI
7	1006BRV.par	1	1/2" HYDRAULIC FILTER
8	16071OIL_asm	1	3 BANK OILER W/ 3 EXTRA MODULES
9	1999FIT.par	6	3/4" X 3/4" HOSE SWIVEL
10	20010FIT.par	7	3/4" SWIVEL CONNECTOR
11	2050FIT.par	1	1/4" TO 1/8" 90 DEG. FITTING
12	2051FIT.par	7	1/4" TO 1/4" 90 DEG. FITTING
13	2052FIT.par	2	1/4" TO 3/8" 90 DEG. FITTING
14	2066FIT.par	1	1/4" TO 1/8" MALE CONNECTOR
15	2071FIT.par	1	3/8" TO 3/8" MALE CONNECTOR
16	20751FIT.par	6	1/8" X 1/8" 90 DEG. SWIVEL
17	20754FIT.par	2	1/4" to 10/32" 90 DEG. FITTING
18	20770PFT.par	1	3/4" X 1/2" BUSHING
19	21010PFT.par	2	1/8" PIPE PLUG
20	21025PFT.par	1	3/8" TEE
21	2111PFT.par	1	1/2" X 1" NIPPLE
22	2124PFT.par	1	3/8" X 1" NIPPLE
23	2130PFT.par	2	1/2" TO 3/8" PIPE REDUCER
24	2154PFT.par	1	1/2" STREET ELL
25	2509BLT.par	2	1/4" X 2 1/2" BOLT
26	2716NUT.par	2	1/4" NYLON LOCK NUT
27	SRS16262.par	1	OIL TANK
28	SRS16480.par	1	OIL TANK CAP

FNG8022-26

# SIDE SHIFT SCHEMATIC

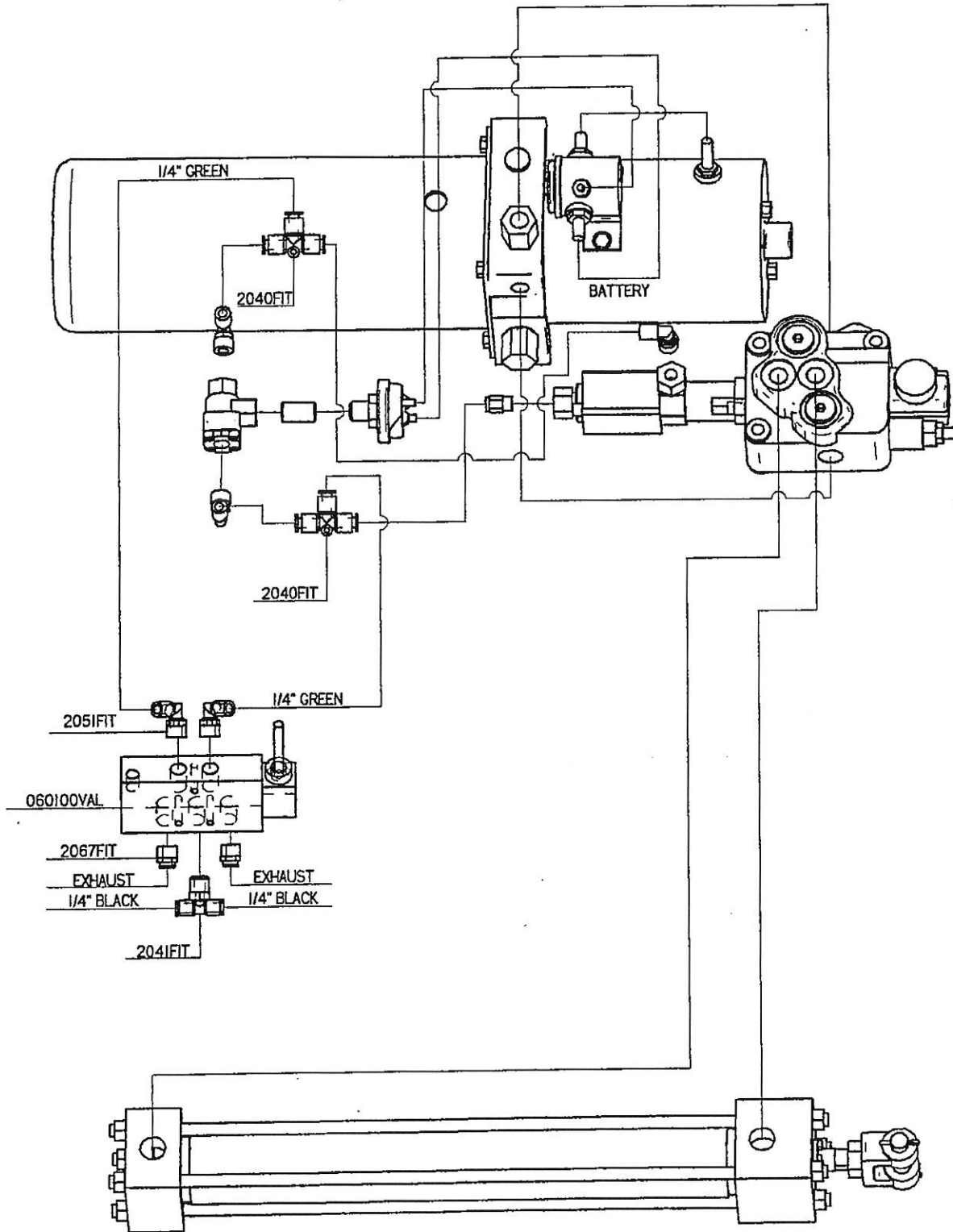

FNG8022-27

# SIDE SHIFT SCHEMATIC

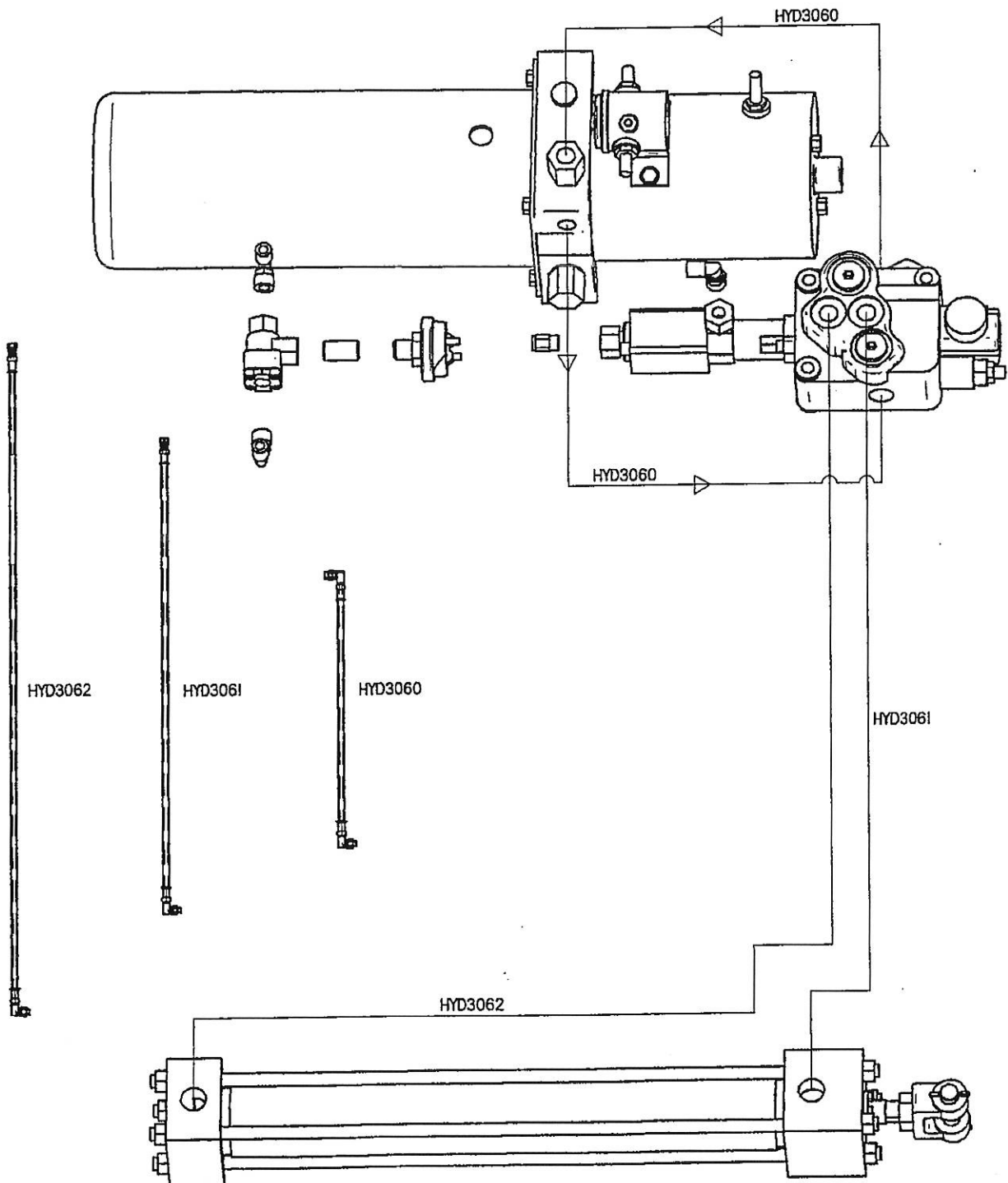

FNG8022-28

# FEED SYSTEM SCHEMATIC

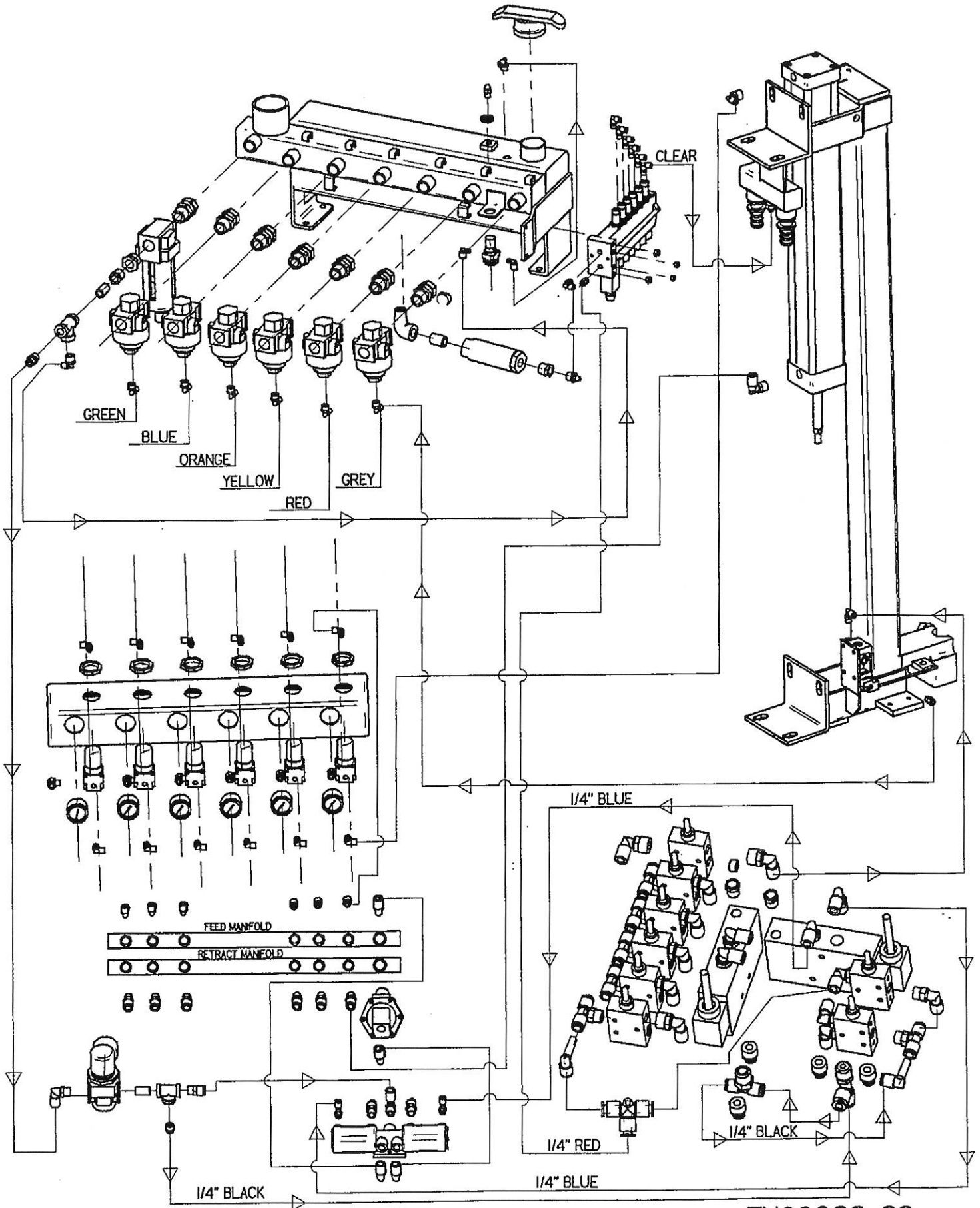

FNG8022-29

# SWING LOCK SCHEMATIC

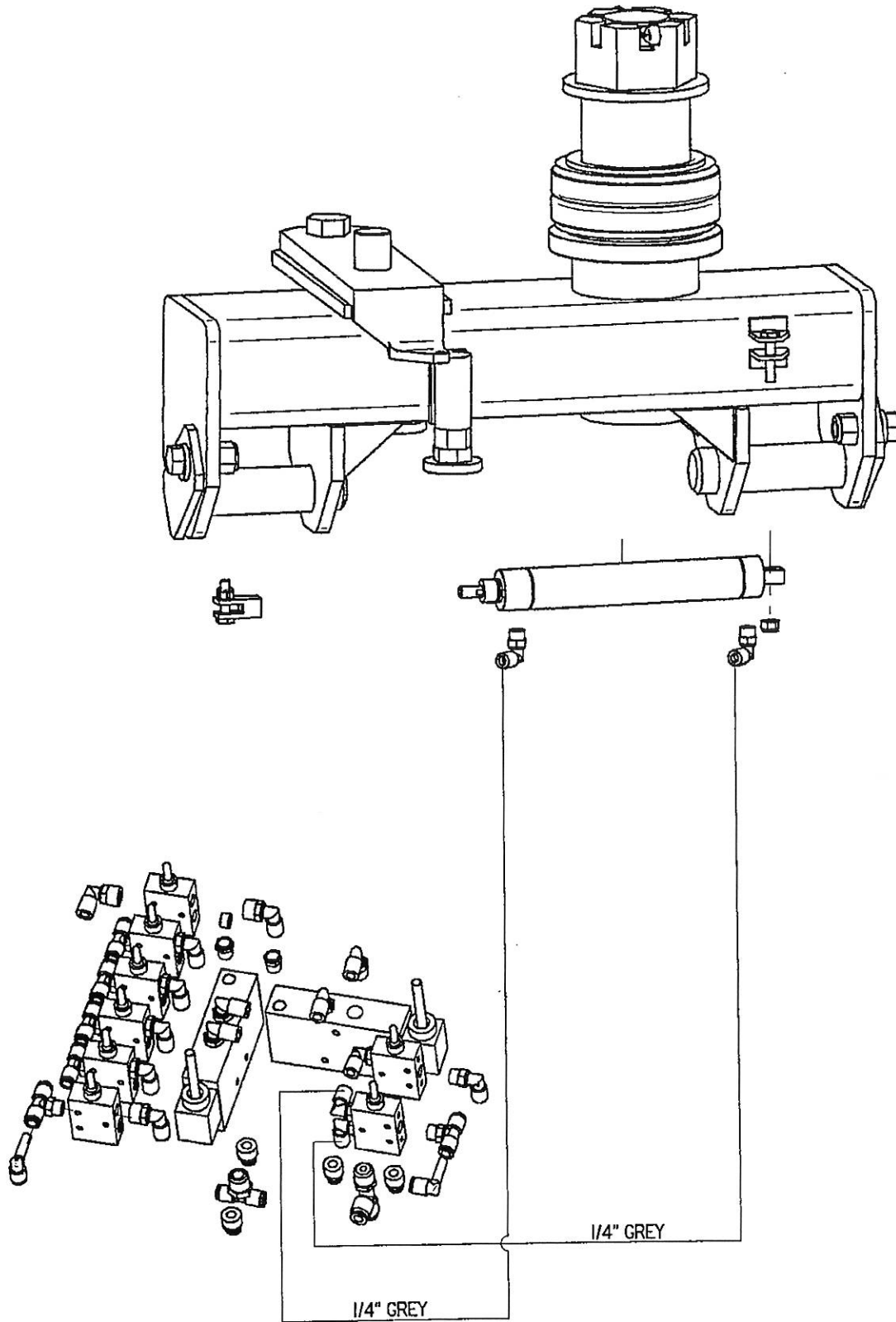

FNG8022-30

# PIN AND BUSHING ASSEMBLY

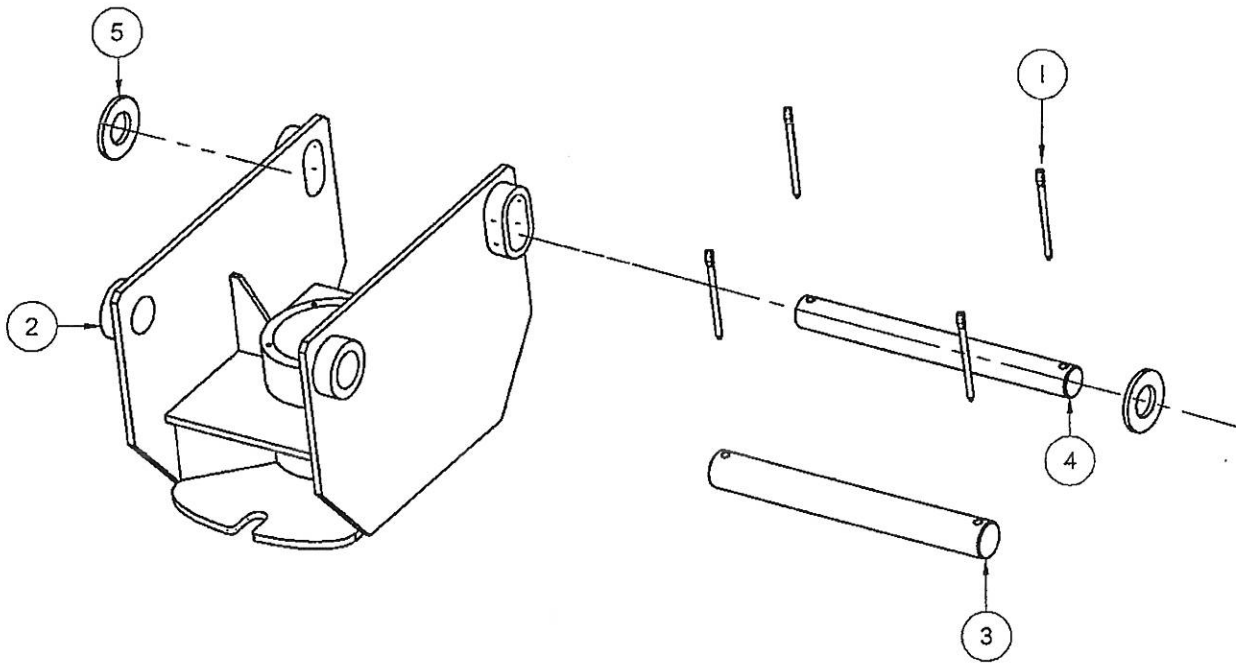

Item Number	File Name	Quantity	Description
1	30227PIN.par	4	5/16" X 4" COTTER PIN
2	HYD3004.par	1	SWIVEL
3	HYD3048.par	1	BOOM PIN   3/4" OD
4	HYD30480.par	1	CURL PIN   1/2" OD
5	HYD30481.par	2	CURL PIN WASHER

FNG8022-31

# OPTIONAL PIN AND BUSHING ASSEMBLY FOR 416 CAT

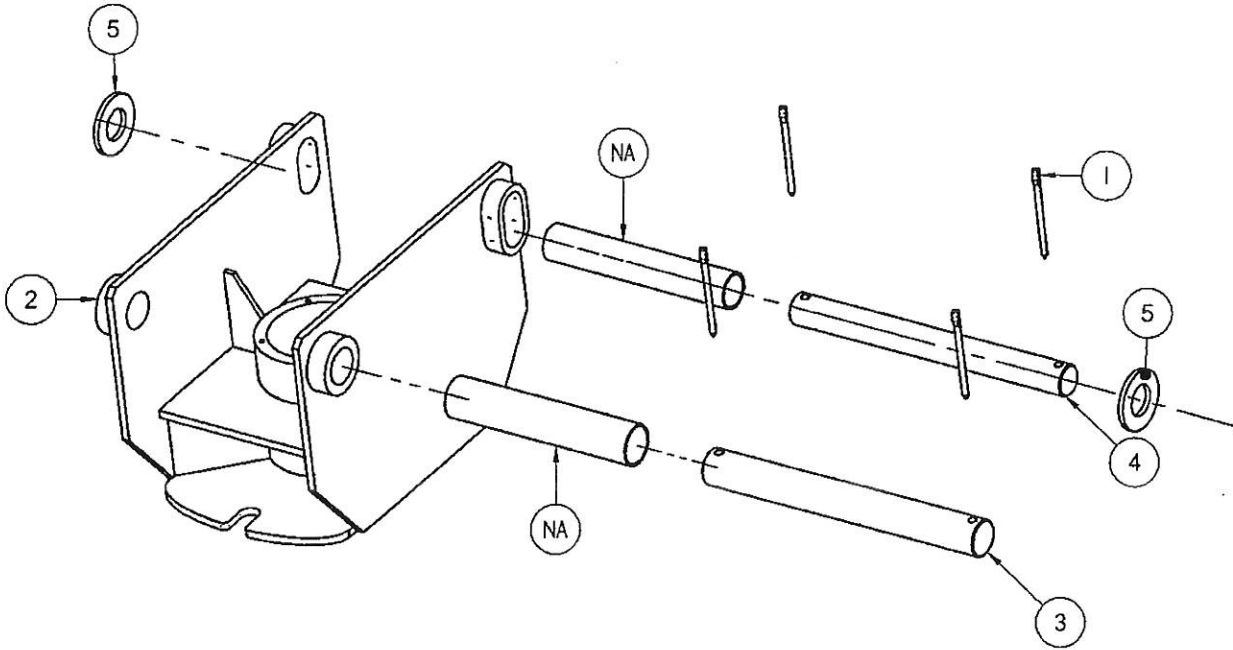

Item Number	File Name	Quantity	Description
1	30227PIN.par	4	5/16" X 4" COTTER PIN
2	HYD3004.par	1	SWIVEL
3	HYD3048.par	1	BOOM PIN   3/4" OD
4	HYD30480.par	1	CURL PIN   1/2" OD
5	HYD30481.par	2	CURL PIN WASHER
6	HYD3600.par	1	CURL PIN BUSHING FOR CAT 416 1.741" OD 1.505" ID
7	HYD3601.par	1	BOOM PIN BUSHING FOR CAT 416 1.967" OD 1.763" ID

FNG8022-32



Spare parts list CP 0032 A 7/8" x 3/4"

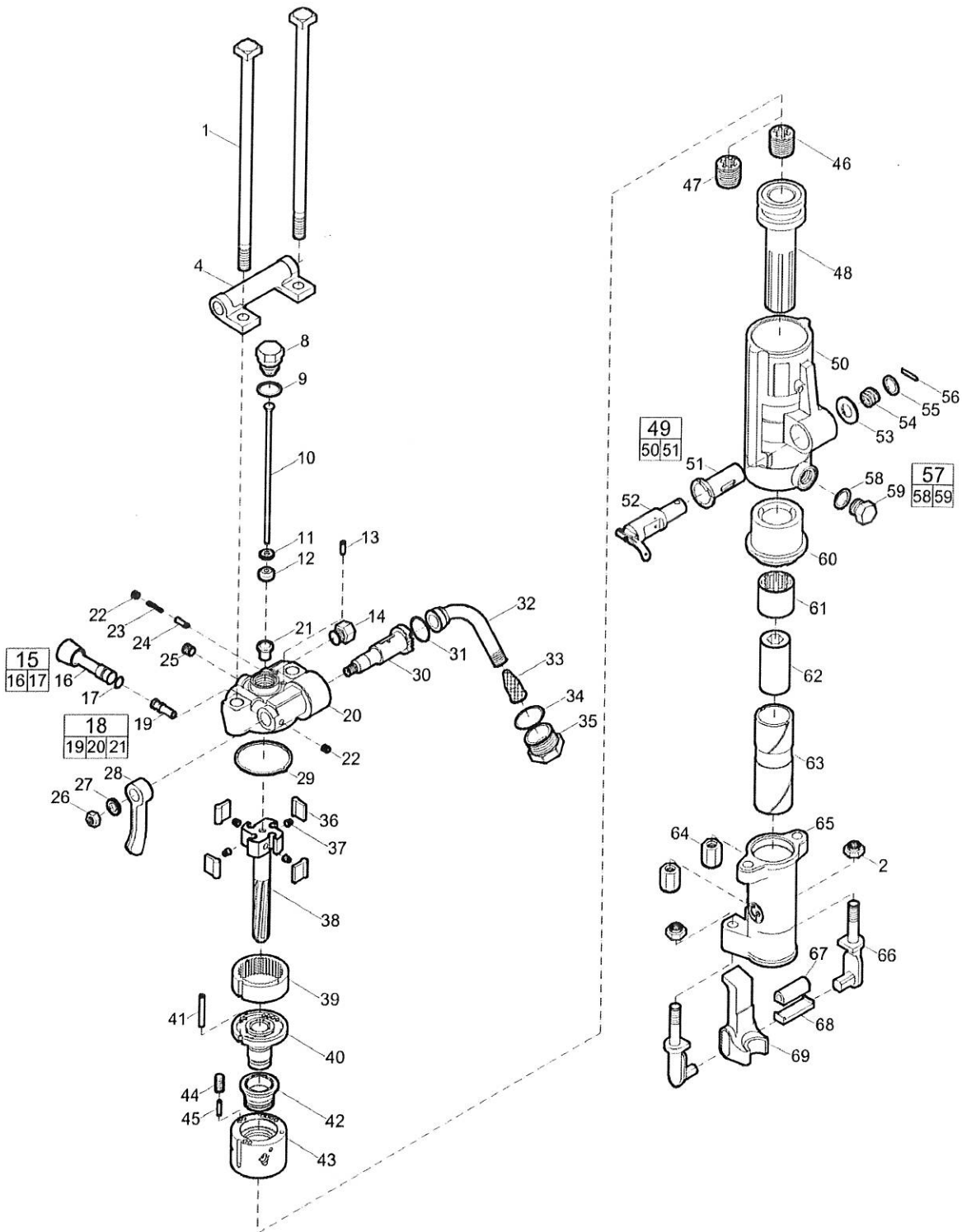

Refer to the Parts Online web page for most up-to-date information. The printed information might be outdated.

Item	Part No.	Name	Qty	L
1	R086623	Bolt - Thru	2	
2	R005742	Nut - Elastic stop	Z	A
4	R086608	Bracket - Handle	1	
8	R076793	Plug - Air tube	1	
9	R000537	Gasket - Tube plug	2	
10	R077184	Tube - Air	1	
11	R075449	Washer - Air tube	1	
12	R075099	Rubber - Air tube	1	
13	R075802	Pin - Valve plunger	1	
14	R076372	Plug - Water valve	1	
15	R079130	Water valve port plug, complete	1	
16	-	Water valve port plug	1	
17	C079489	O-ring	1	
18	R087948	Backhead, complete	1	
19	R098054	Bushing - Water valve	1	
20	-	Backhead	1	
21	R137738	Bushing - Blow tube	1	
22	C068064	Plug - Pipe	2	
23	R085671	Spring - Valve plunger	1	
24	R086627	Plunger - Throttle valve	1	
25	C068799	Plug - pipe, Ø 1/4 in., Ø 6.5 mm	1	C
26	P002149	Nut - Hexagon	1	D
27	C036717	Lockwasher - Head latch	1	E
28	R079124	Handle - Throttle valve	1	
29	H0979432	Gasket	1	
30	R086628	Valve - Throttle	1	
31	P103521	O-ring	1	
32	R075265	Swivel - Air inlet	1	
33	R005584	Screen - Air inlet	1	
34	R110317	O-ring	1	
35	R000530	Air swivel nut	1	
36	R075267	Pawl	4	
37	R086654	Spring - Pawl	4	
38	R086622	Bar - Rifle	1	

Refer to the Parts Online web page for most up-to-date information. The printed information might be outdated.

Item	Part No.	Name	Qty	L
39	R076194	Ring - Ratchet	1	
40	R098085	Bushing - Valve guide	1	
41	R075772	Pin - Valve case dowel	1	
42	R076263	Valve	1	
43	R076264	Case - Valve	1	
44	R098084	Plug - Oil regulating	1	
45	R085625	Stem - Oil regulating	1	
46	R075839	Nut - Rifle bar	1	F
47	R075826	Nut - Rifle bar	1	G
48	R000088	Piston	1	
49	R087990	Cylinder, complete	1	
50	--	Cylinder	1	
51	R086611	Bushing - Blower valve	1	
52	R086612	Valve - Blower	1	
53	R075777	Washer - Blower valve	1	
54	R075778	Spring - Blower valve	1	
55	R075780	Washer - Valve spring	1	
56	R076266	Pin - Spring	1	
57	R085611	Oil plug, complete	1	
58	R091176	Gasket - Oil plug	1	
59	--	Oil plug	1	
60	R042161	Bushing - Cylinder	1	
61	R086733	Nut - Chuck rotation	1	
62	R099374	Chuck, 7/8" x 31/4" (22 x 82.5 mm)	1	
63	R041321	Sleeve - Chuck, 7/8" x 31/4" (22 x 82.5 mm)	1	
64	R085756	Nut - Thru bolt	2	
65	R041320	Fronthead, 7/8" x 31/4" (22 x 82.5 mm)	1	
66	R093896	Tunnion - Retainer	2	
67	R093897	Buffer - Retainer	1	
68	R093898	Retainer - Latch shoe	1	
69	R093913	Retainer, 7/8" (22 mm)	1	

Comments for Page: CP 0032 A 7/8" x 3 1/4"

(L)OCAL REMARKS

A | 5/8" - 11

B | 1/8"

C | 1/4"

Refer to the Parts Online web page for most up-to-date information. The printed information might be outdated.



# L50M2 Multi-Point Injection Lubricator

Operating Pressure Range 30-150 PSIG

Max. Press.	Max. Temp.	Oil Flow Delivery Range	Oil Viscosity
150 PSI	120° F	0-1 Drop	150 thru 1200 SSU

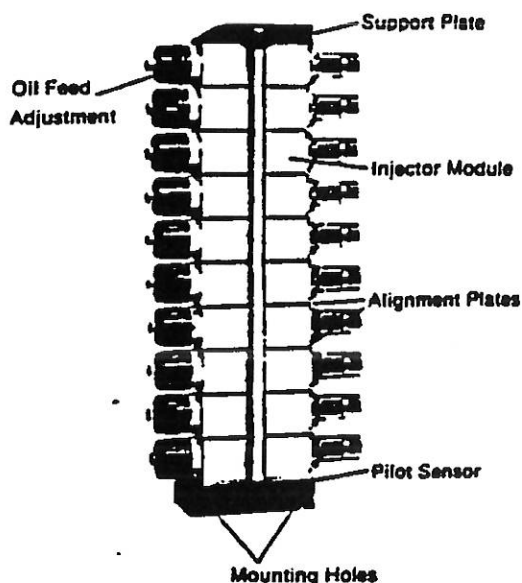

Typical Installation (A)  
(Pilot Sensor)

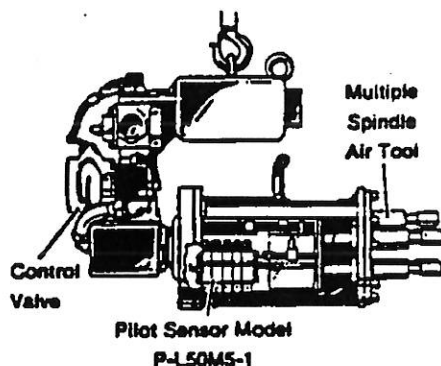

**WARNING!** Never use these polycarbonate plastic bowls in air supplied by a compressor lubricated with synthetic oils or oils containing phosphate esters or chlorinated hydrocarbons. They can carry-over into the air distribution system and chemically attack and possibly rupture the bowls. On these applications use a metal bowl. Also, do not expose these polycarbonate plastic bowls to materials such as carbon tetrachloride, trichlorethylene, acetone, paint thinner, cleaning fluids, or other harmful materials, for they too will craze and/or rupture the bowl. If materials harmful to polycarbonate are present either outside or inside the bowl, use a metal bowl.

## Installation, Operating and Maintenance Instructions

### Application

The Watts L50M2 Multi-point Injection Lubricator is specifically designed to lubricate intermittently operated air rotary tools, cylinders and valves. If equipment operates continuously, the L50M2 must be triggered by a separate signal such as from a timer and solenoid valve arrangement. Unlike conventional mist type lubricators, the L50M2 delivers, via capillary tubes, small, precisely controlled amounts of lubricant right to the end lubrication points in the system every time the equipment is cycled (operated). The L50M2 consists of a sensor (pilot), one to ten injector modules, alignment plates, support plate as described below, and oil reservoir (see Fig. 3).

### Sensor

The sensor is a pilot sensor (Fig. 1). The pilot sensor receives a pressure pulse (signal) from an external source and transmits it to all the injector modules in the stack. The pilot sensor is normally used on multiple spindle rotary air tools. As shown in Typical Installation (A), the pilot signal is tapped off at a point downstream of the control valve so that injector is fired during the "ON" cycle. Also, it is essential that the pilot signal be removed (vented to atmosphere through the tool) during the "OFF" cycle. The pilot sensor is also used on cylinder and valve circuits by taking the pilot signal from the downstream side of the valve. A separate three-way solenoid operated or air pilot operated valve may be used if it is not convenient or possible to obtain pilot signal directly from the operating circuit. If it is desirable to lubricate one group of points during one portion of the machine (circuit) operating cycle, and another group at a different time, two L50M2's must be used.

**NOTE:** Install filter and regulator, such as Watts C20 FR, upstream of L50M2.

### Typical Installation (B)

Single Point Lubrication  
from each Module

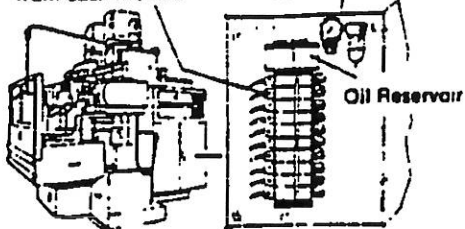

Pilot Sensor Model  
P-L50M 10-4

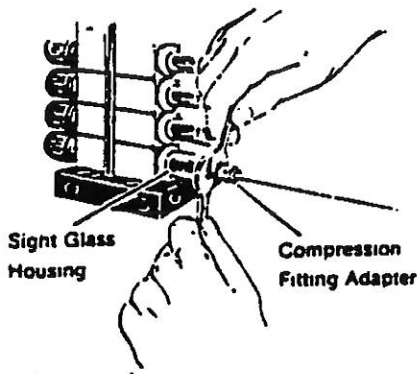

Sight Glass  
Housing

Compression  
Fitting Adapter

### Injector Modules

The injector modules are basically air operated, positive displacement, adjustable delivery oil pumps. The oil feed rate is adjustable from 0-1 drop (0-032 cc's) per pulse. Air signal and oil supply passes through each injector module to the next one in the stack. Sight glass, tamperproof oil feed adjustment and manual override pump are provided for ease of operation.

### Reservoir

Any reservoir may be used to store and supply oil to the L50M2 injector module stack. It can be gravity fed or pressurized (up to 100 psi)\*. Normally the 8 ounce (No. 610-4RQ)\*, one quart (BKLS0B)\*\* or two quart (BKLS0C)\*\* reservoir is used. Where there are many L50M2's, oil can be supplied from a central fill system which is supplied by a 55-gallon drum as the reservoir.

\*Only the (610-4RQ) can be pressurized.

\*\*Must be remote mount.

### Capillary Tubing

Oil is delivered from each injector module to the point of use via a 1/8" O.D. capillary tube. Either a compression or barbed adapter is used to connect the tubing to each 1/8" NPT female injector oil outlet. A ball check adapter (1/8" O. D. Tubex 1/8" NPT male) is used on the other end of tubing. The ball check prevents foaming of oil in tubing during "Off" cycle. It is preferable to inject oil into air line immediately upstream of equipment to be operated. Then, oil is transported into equipment on the "On" cycle where it disperses over the wetted surfaces. Once equipment is initially "wetted down", only a very, very small amount of lubricant—normally 0.1 to 0.2 drops per cycle are required to maintain the desired lubrication.

### Installation

Install L50M2 Injector module stack in a convenient location on or close to operating equipment. It is preferable that machine operator can observe movement of red indicator inside sight glass (see Fig. 2) and be able to make changes to oil feed adjustment as may be desired.

Normally the stack is installed in a vertical position primarily so that air bubbles in the oil will rise to the top. Mount L50M2 rigidly to equipment or to separate support via two mounting holes in pilot sensor (see Fig. 1).

Connect oil feed capillary tubing to each injector sight glass outlet, utilizing 1/8" NPT male to 1/8" O. D. tube compression fitting adapter (Part No. SA-L50Y139). Grip wrench flats on outer sight glass housing to prevent it from rotating when installing tubing adapter—(see Fig. 2). Once installed, rotate sight glass housing so that red plunger inside the sight glass may be conveniently observed.

Next, run capillary tubing to point of use, appropriately securing tubing to supporting member (pipeline, column, machine frame, etc.) along the way. Since the injector is a positive displacement device, capillary may be run for hundreds of feet, uphill, downhill without jeopardizing L50M2's performance. Do not pass tubing next to extremely hot (steam lines) or cold (refrigeration units) points for it will impair capillary's strength and change oil's viscosity. At point of use, which is as close to inlet port of air operated equipment as possible, cut capillary and install ball check connector (Part No. SA-606Z26).

Next, place oil reservoir in location where it will be convenient to observe oil level and refill when necessary. (Do not let reservoir run dry). It is preferable to locate reservoir so that oil may flow by gravity to the top or bottom (or both) supply connection in the support plate of the stack. If reservoir must be located below the top of injector module stack, provide means for delivering oil (via pump or pressurized reservoir—up to 100 psi) to L50M2. It is preferable to install shut-off valve, Watts P2-1/4" F x 1/4" M, in oil supply line between reservoir and injector so that maintenance may be performed on one without having to disturb the other.

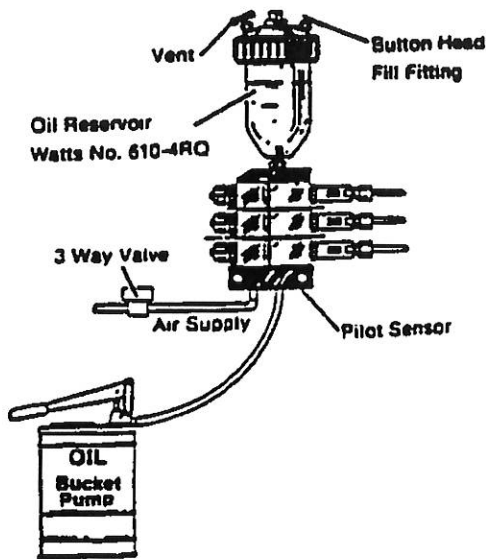

## OIL FEED ADJUSTMENT

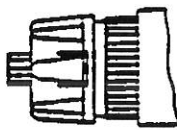

1. Push forward to adjust oil delivery.

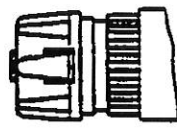

2. Pull to rear to lock position.



3. Completely remove knob to make setting tamperproof.

## Priming System

Once system is completely piped in, the next step is to fill the reservoir, purge air from system and fill capillary tubing. The simplest way is to install a button head fill fitting (Watts Part No. SA-606Y107) on one of the oil supply ports in the support plate or sensor body. Open vent on reservoir, then, with the aid of a bucket pump, pump oil back up into the reservoir (see Fig. 3). Once reservoir is full, close vent and continue to pump. (If reservoir is not pressure type, close shut-off valve in supply line.) The bucket pump will overcome check valve in injector and oil will be forced down each injector's capillary tube. Once longest tube is filled, disconnect bucket pump and open reservoir vent (open oil supply shut-off valve if previously closed).

Manual filling is more time-consuming. Reservoir is first filled, and air is purged from stack by removing lower-most plug. Then, each injector is adjusted to maximum setting (see "Oil Feed Adjustment") and cycled manually by repeatedly pushing and releasing manual pump or automatically by cycling equipment. Approximately 50 cycles are required to purge each foot of capillary tube.

## Oil Feed Adjustment

Push in red adjustment knob (see Fig. 4) to unlock. Turn knob clockwise to stop. The injector is now adjusted for maximum oil output—approximately 1 drop per cycle (.032 cc).

Operate downstream equipment until all wetted surfaces are coated with oil and excessive oil mist is discharging from operating equipment exhaust ports. Next, reduce oil adjustment by turning red knob counter-clockwise. Each counter-clockwise turn reduces oil rate by 0.1 drop/cycle. A normal setting is 2½ to 3½ turns counter-clockwise (i.e. 0.3-0.2 drops/cycle). Operate equipment for few cycles and re-adjust to a higher (clockwise) or lower (counter-clockwise) oil delivery setting as may be required. When set, pull knob rearward one click to lock setting. Remove knob to make tamperproof. To completely shut off oil feed, turn knob 6-8 turns counter-clockwise. Repeat procedures for each injector in the stack.

## Troubleshooting

First indication of malfunction is the red indicator in the sight glass (see Fig. 6) is not moving when injector is cycled and all other parts, such as manual pump, sensor, etc. function normally. To correct problem, first re-adjust oil feed setting to maximum by turning red oil feed adjustment knob all the way clockwise and observing number of turns and location of arrow on the end of knob. If the red indicator now moves when injector is cycled, it is functioning properly and can be re-adjusted back to lower setting. However, continue to observe if red indicator does move as knob is turned counter-clockwise. Normally motion will not be noticeable below 3½ to 4 turns back and lubricator will be completely shut off at 5½ to 6 turns back. If indicator still does not move after oil delivery is at maximum, the malfunction may be caused by an air pocket in injector oil passages. To remedy, purge the injector module stack by removing the ¼" pipe oil plug in plate (see Fig. 6). Recycle injector. If injector was air-bound, normally a few small air bubbles will now emerge in the sight glass and be purged out through capillary tubing. Prevent the formation of air pockets by not allowing reservoir to run out of oil.

If neither of the above simple procedures correct problem, it is normally good practice to replace the malfunctioning module with a new one and put equipment back into operation. Then, the malfunctioning module can be disassembled, cleaned and repaired at leisure (see Fig. 5).

If manual pump is not moving when equipment is cycled, air signal is not reaching injector(s).

First determine if signal is being delivered to modules. If not, check air circuit and/or control valve for proper operation.

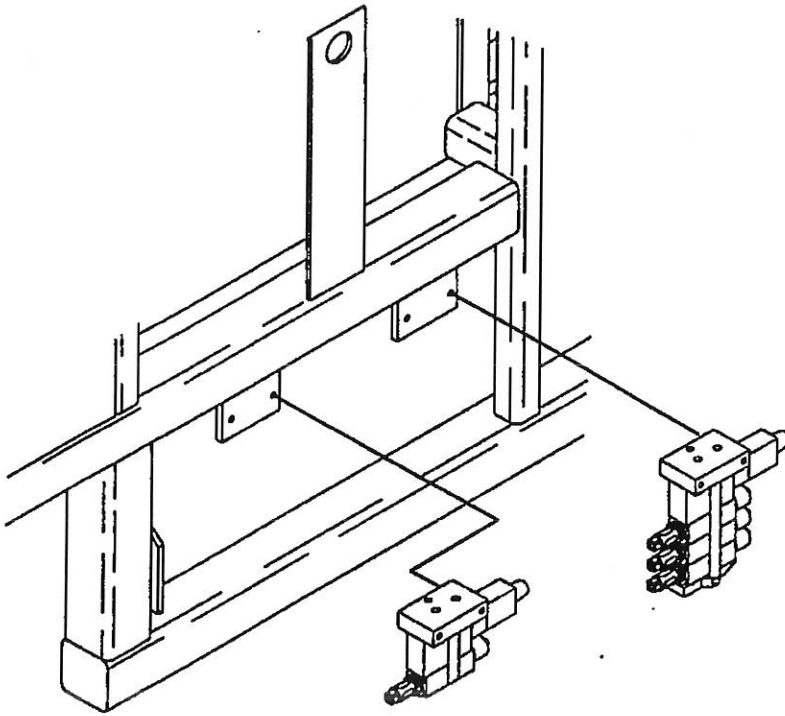

REPAIR KITS:

1757RPT

- OIL PISTON SPRING
- OIL PISTON
- ADJUSTMENT KNOB
- ADJUSTMENT ASSEMBLY

1757ORPT

- INDICATOR CYLINDER
- INDICATOR CYLINDER O-RING
- INDICATOR PISTON
- INDICATOR PISTON SPRING
- CHECK BALL
- CHECK BALL SPRING
- HOUSING RETAINER
- SIGHT GLASS HOUSING
- SIGHT GLASS HOUSING O-RING

